

## ■ General Description

The AME4621 is Dual Single Pole Double Throw (SPDT) analog switches with wide operating single power supply voltage range, from 1.8V to 5.5V.

AME4621 has 1Ω max ON resistance when +5V power supply is used. These products also have fast switching speeds,  $t_{ON} = t_{OFF} = 50\text{nS}$  max.

AME4621 is available in DFN-10B.

## ■ Features

- Low  $R_{ON}$
- Wide Operation Supply Voltage: 1.8V to 5.5V
- Fast Switching Time:  $t_{ON} = t_{OFF} = 50\text{nS}$  max.
- TTL-Logic Compatible
- Over Thermal Protection
- Space Saving in DFN-10B
- All AME's Lead Free Product Meet RoHS Standards

## ■ Applications

- Power Routing
- Battery-Operated Equipment
- Audio and Video Signal Routing
- Low-Voltage Data-Acquisition Systems
- Communications Circuits
- PCMCIA Cards
- PC Peripherals

## ■ Functional Block Diagram

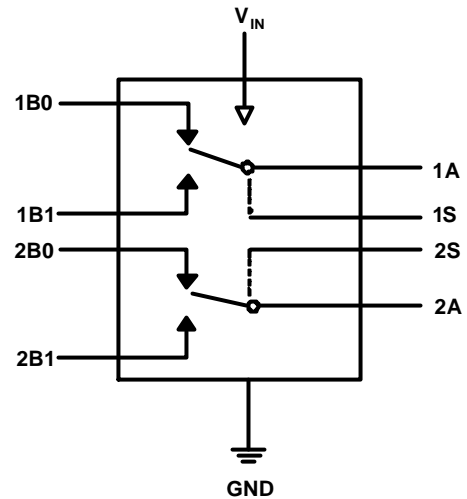

Control Input(s)	Function
L	B0 connected to A
H	B1 connected to A

H: High Logic Level

L: Low Logic Level

## AME4621

### ■ Pin Configuration

DFN-10B  
(3mmx3mmx0.75mm)  
Top View

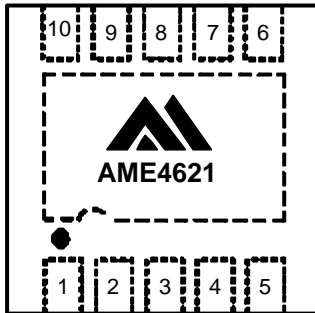

#### AME4621AEVB

1. GND
2. 1B1
3. 1S
4. IN
5. 2S
6. 2A
7. 2B1
8. 2B0
9. 1A
10. 1B0

\* **Die Attach:**  
**Conductive Epoxy**

### ■ Pin Description

Pin Number	Pin Name	Pin Description
3, 5	1S, 2S	Digital Control Input
4	IN	Supply Voltage Input
1	GND	Ground
10, 8	1B0, 2B0	Data Port Function
9, 6	1A, 2A	Data Port Function
2, 7	1B1, 2B1	Data Port Function

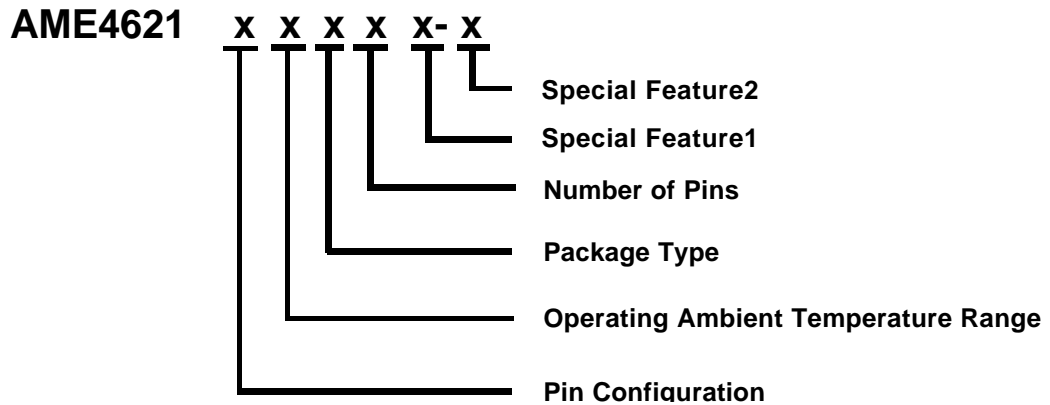
**■ Ordering Information**

Pin Configuration	Operating Ambient Temperature Range	Package Type	Number of Pins	Special Feature1	Special Feature 2 (For DFN package only)
A: 1. GND (DFN-10B) 2. 1B1 3. 1S 4. IN 5. 2S 6. 2A 7. 2B1 8. 2B0 9. 1A 10. 1B0	E: -40°C to +85°C	V: DFN	B: 10	Z: Lead free	3: 3x3x0.75(mm) (LxWxH)

**■ Ordering Information**

Part Number	Marking*	Activity Mode	Package	Operating Ambient Temperature Range
AME4621AEVBZ-3	BFQ yyww	Break-Before-Make	DFN-10B	- 40°C to +85°C

Note: yyww represents the date code.

\* A line on top of the first letter represents lead free plating such as  $\overline{\text{BFQ}}$ ww.

Pls consult AME sales office or authorized Rep./Distributor for the availability of package type.

**AME4621**
**■ Absolute Maximum Ratings**

Parameter	Maximum	Unit
$V_{IN}$ , 1S, 2S	6	V
1A, 2A, 1B0, 2B0, 1B1, 2B1	Note 1	V
Continuous Current 1A, 2A, 1B0, 2B0, 1B1, 2B1	300	mA
ESD Classification	B*	

Note1: Signals on 1A, 2A, 1B0, 2B0, 1B1, 2B1 can not exceed  $V_{IN}$

Caution: Stress above the listed absolute maximum rating may cause permanent damage to the device.

\* HBM B:2000V~3999V

**■ Recommended Operating Conditions**

Parameter	Symbol	Rating	Unit
Ambient Temperature Range	$T_A$	- 40 to +85	°C
Junction Temperature Range	$T_J$	- 40 to +125	°C
Storage Temperature Range	$T_{STG}$	- 65 to +150	°C
1S, 2S	CMOS, TTL Logic		V
$V_{IN}$	1.8 to 5.5		V

**■ Thermal Information**

Parameter	Package	Die Attach	Symbol	Maximum	Unit
Thermal Resistance* (Junction to Case)	DFN-10B	Conductive Epoxy	$\theta_{JC}$	17	°C / W
Thermal Resistance (Junction to Ambient)			$\theta_{JA}$	125	
Internal Power Dissipation			$P_D$	800	mW
Maximum Junction Temperature				150	°C
Solder Iron (10 Sec)**				350	°C

\* Measure  $\theta_{JC}$  on center of molding compound if IC has no tab.

\*\* MIL-STD-202G 210F

**■ Electrical Specifications**

$V_{IN} = +5V \pm 10\%$ ,  $GND = 0V$ ,  $1S_H = 2S_H = 2.4V$ ,  $1S_L = 2S_L = 0.8V$ ,  $T_A = -40^\circ C$  to  $+85^\circ C$ , unless otherwise noted. Typical values are at  $T_A = 25^\circ C$ .

Parameter	Symbol	Test Condition	Min	Typ	Max	Units	
<b>ANALOG SWITCH</b>							
On-Resistance	$R_{ON}$	$V_{IN} = 4.5V$ $I_{1A, 2A} = 100mA$	$T_A = 25^\circ C$			1.0	$\Omega$
			$T_A = -40^\circ C$ to $+85^\circ C$			1.2	
On-Resistance Match between channels	$\Delta R_{on}$	$V_{IN} = 4.5V$ $I_{1A, 2A} = 100mA$ $V_{1B1, 2B1}$ or $V_{1B0, 2B0} = 3.5V$	$T_A = 25^\circ C$			0.12	$\Omega$
			$T_A = -40^\circ C$ to $+85^\circ C$			0.15	
On-Resistance Match Flatness	$R_{FLATE}$	$V_{IN} = 4.5V$ $I_{1A, 2A} = 100mA$ $V_{1B1, 2B1} = 0V, 1V, 2V$ $V_{1B0, 2B0} = 0V, 1V, 2V$	$T_A = 25^\circ C$		0.15	0.2	$\Omega$
			$T_A = -40^\circ C$ to $+85^\circ C$			0.2	
Switch Off-Leakage Current	$I_{1B1, 2B1(OFF)}$ $I_{1B0, 2B0(OFF)}$	$V_{IN} = 5.5V$ $V_{1A, 2A} = 1V, 4.5V$ $V_{1B0, 2B0} = 4.5V$ or $1V$ $V_{1B1, 2B1} = 4.5V$ or $1V$	$T_A = 25^\circ C$	-0.1	0.05	0.1	$\mu A$
			$T_A = -40^\circ C$ to $+85^\circ C$	-1.0		1.0	
<b>DIGITAL I/O</b>							
Input Logic High	$1S_H, 2S_H$	$V_{IN} = 5.5V$		2.4			V
Input Logic Low	$1S_L, 2S_L$					0.8	
Input Current Logic High or Low	$I_{1S}, I_{2S}$	$V_{1S} = V_{2S} = V_{IN} (0V)$		-1.0		1.0	$\mu A$
<b>SWITCH DYNAMIC CHARACTERISTICS</b>							
Turn-On Time	$t_{ON}$	Figure 1	$T_A = 25^\circ C$			50	ns
			$T_A = -40^\circ C$ to $+85^\circ C$			60	
Turn-Off Time	$t_{OFF}$	Figure 1	$T_A = 25^\circ C$			50	ns
			$T_A = -40^\circ C$ to $+85^\circ C$			60	
Break-Before-Make Delay	$t_{BBM}$	Figure 2	$T_A = 25^\circ C$	1	20		ns
			$T_A = -40^\circ C$ to $+85^\circ C$	1			
<b>POWER SUPPLY</b>							
Power Supply Range	$V_{IN}$		$T_A = -40^\circ C$ to $+85^\circ C$	1.8		5.5	V
$V_{IN}$ Supply Current	$I_{IN}$	$V_{IN} = 5.5V$ , $1S, 2S = 0V$ or $V_{IN}$	$T_A = -40^\circ C$ to $+85^\circ C$			10.0	$\mu A$

**■ Timing Diagrams**

**Figure 1  
Switching Time**

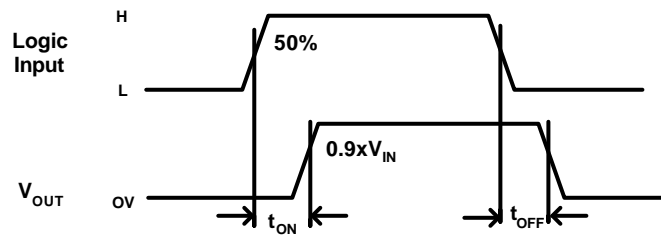
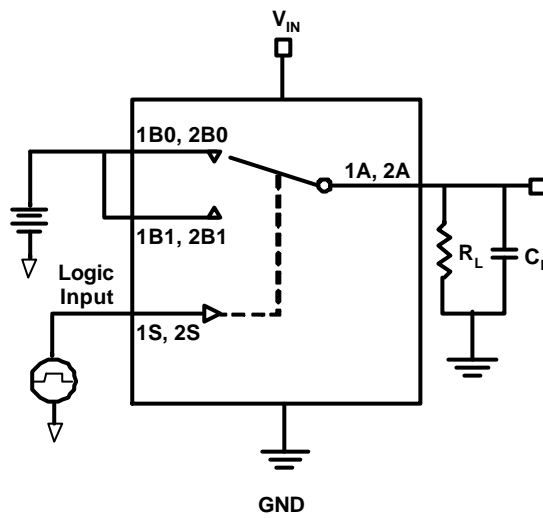

**■ Timing Diagrams**

**Figure 2**  
**Break-Before-Make Interval**

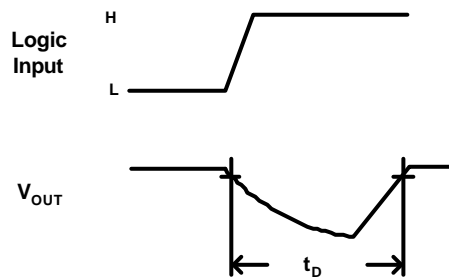
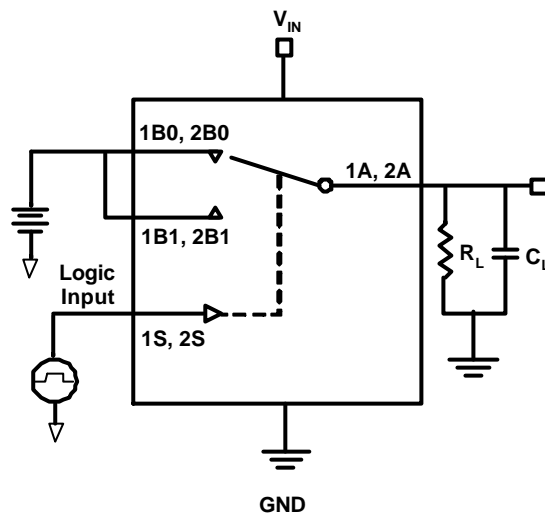

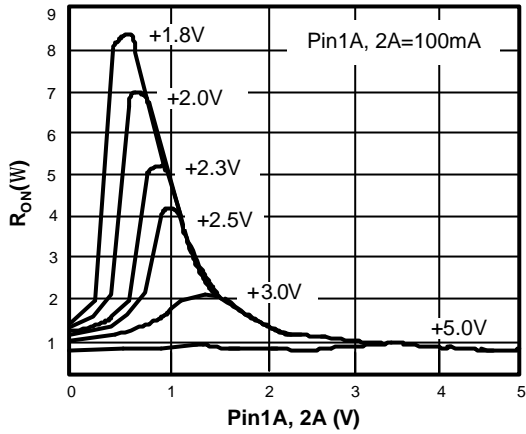
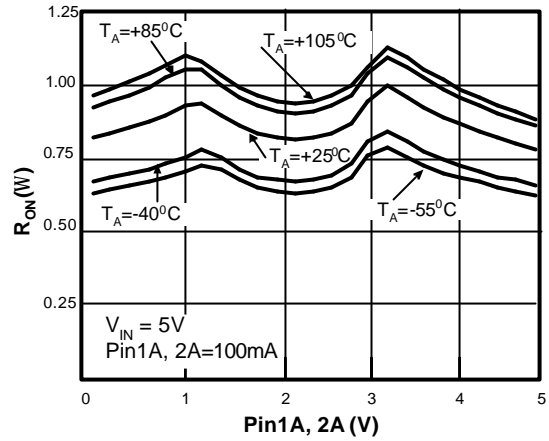
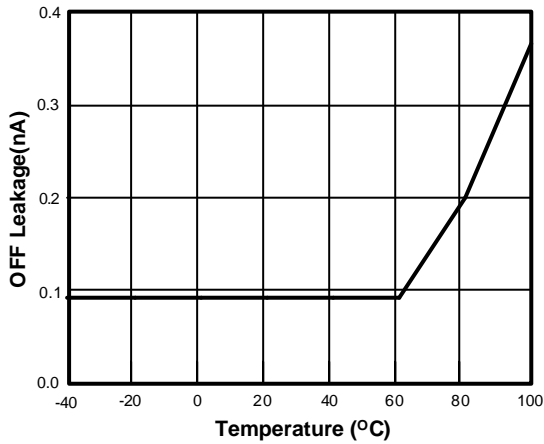
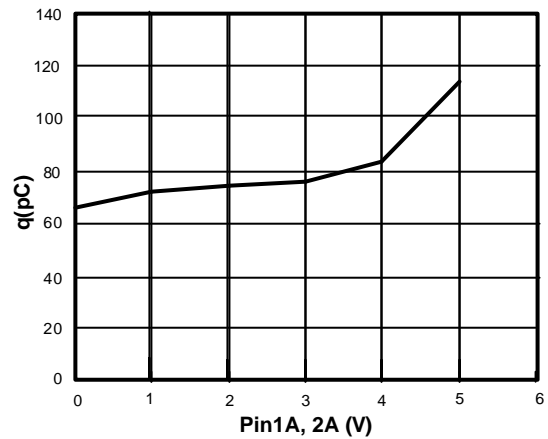
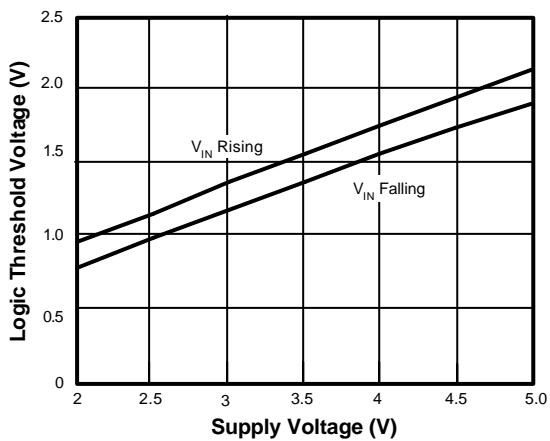
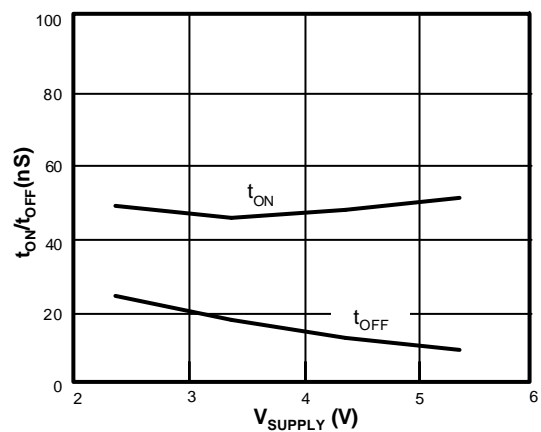
**Ron vs. Pin1A, 2A Voltage over Supply Voltage**

**Ron vs. Pin1A, 2A Voltage over Temperature**

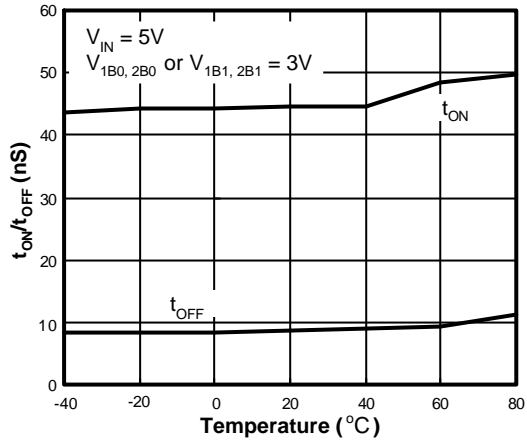
**OFF Leakage vs. Temperature**

**Charge Injection vs. Pin1A, 2A Voltage**

**Logic Threshold Voltage vs. Supply Voltage**

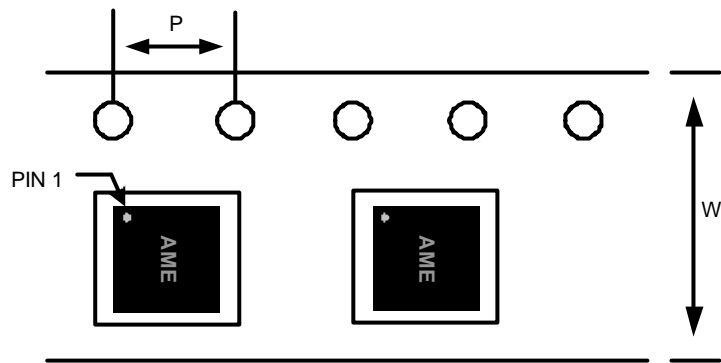
**TURN-ON/OFF Times vs. Supply Voltage**

TURN-ON/OFF Times vs. Temperature



**AME4621**
**■ Taping & Reel Dimension**

**DFN-10B**  
(3mmx3mmx0.75mm)



**Carrier Tape, Number of Components Per Reel and Reel Size**

Package	Carrier Width (W)	Pitch (P)	Part Per Full Reel	Reel Size
DFN-10B (3x3x0.75mm)	12.0±0.1 mm	4.0±0.1 mm	3000pcs	330±1 mm

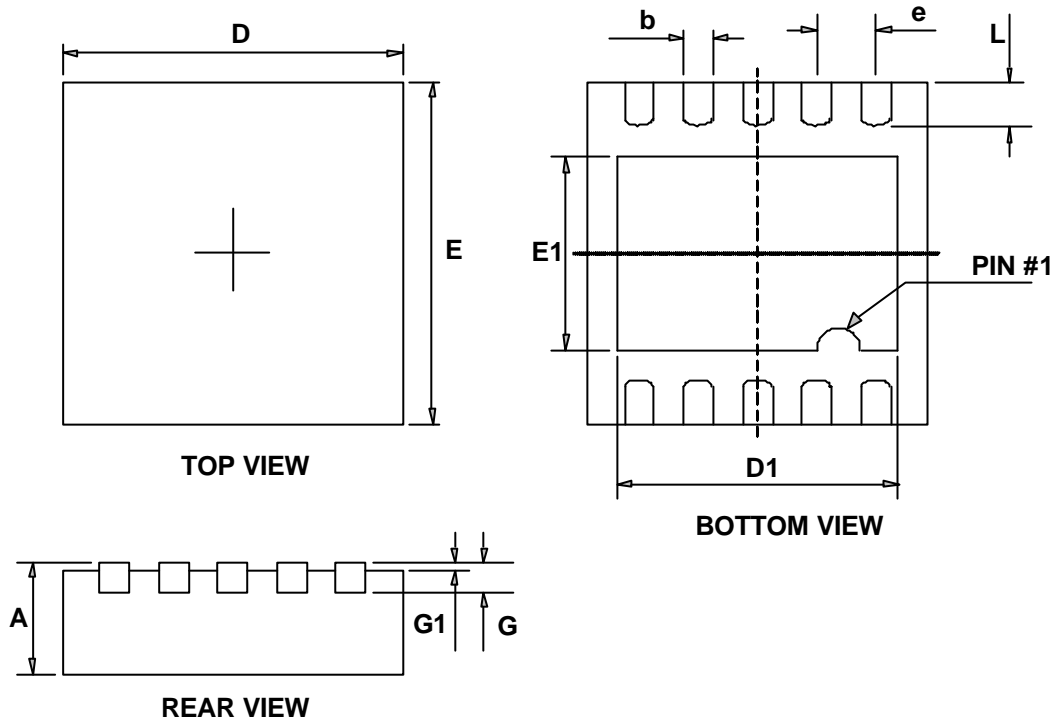
**■ Package Dimension**
**DFN-10B (3mmx3mmx0.75mm)**

SYMBOLS	MILLIMETERS		INCHES	
	MIN	MAX	MIN	MAX
<b>A</b>	0.700	0.800	0.028	0.031
<b>D</b>	2.900	3.100	0.114	0.122
<b>E</b>	2.900	3.100	0.114	0.122
<b>e</b>	0.450	0.550	0.018	0.022
<b>D1</b>	2.350	2.450	0.093	0.096
<b>E1</b>	1.650	1.750	0.065	0.069
<b>b</b>	0.200	0.300	0.008	0.012
<b>L</b>	0.300	0.500	0.012	0.020
<b>G</b>	0.153	0.253	0.006	0.010
<b>G1</b>	0.000	0.050	0.000	0.002



**www.ame.com.tw**  
**E-Mail: sales@ame.com.tw**

Life Support Policy:

These products of AME, Inc. are not authorized for use as critical components in life-support devices or systems, without the express written approval of the president of AME, Inc.

AME, Inc. reserves the right to make changes in the circuitry and specifications of its devices and advises its customers to obtain the latest version of relevant information.

© AME, Inc. , November 2008  
Document: 2105-DS4621-C.03

## **Corporate Headquarter**

### **AME, Inc.**

2F, 302 Rui-Guang Road, Nei-Hu District

Taipei 114, Taiwan .

Tel: 886 2 2627-8687

Fax: 886 2 2659-2989