

■ General Description

The AME7739 is a charge pump voltage converter that delivers a regulated output. No external inductor is required for operation. Using three small capacitors, the AME7739 can deliver up to 60mA to the voltage regulated output. The AME7739 features very low output ripple and high efficiency over a large portion of its load range making this device ideal for battery-powered applications. Furthermore, the combination of few external components and small package size keep the total converter board area to a minimum in space restricted applications.

The AME7739 contains a thermal management circuit to protect the device under continuous output short circuit conditions.

The AME7739 is available in SOT-26 package and is rated from -40°C to +85°C.

■ Features

- Output Voltage Range:
5.5V, 5V, 3.3V, 3.0V, 2.7V, 2.5V
- Accurate to with $\pm 5\%$
- 1MHz Switching Frequency
- Shutdown Supply Current < 1 μ A
- Short Circuit Protection: Typ. 80mA
- Over Temperature Protection
- All AME's Lead Free Product Meet RoHS Standards

■ Applications

- Cellular Phone
- Digital Camera
- PDAs LCD display
- LED/Display Back Light Driver
- Smart Card Reader
- SIM Card Supply
- PCMCIA Card
- LCD Display

■ Functional Block Diagram

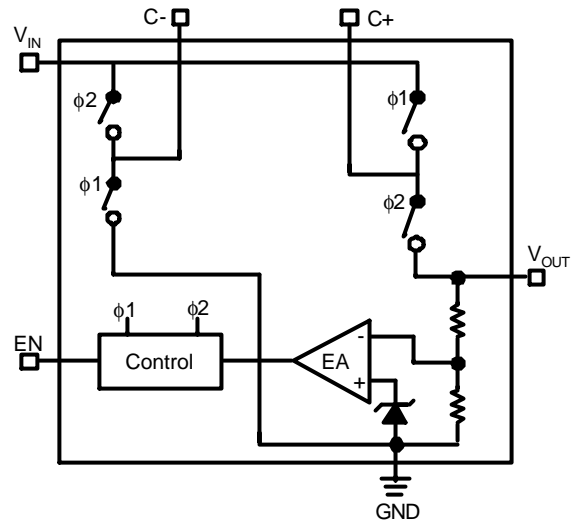

■ Typical Application

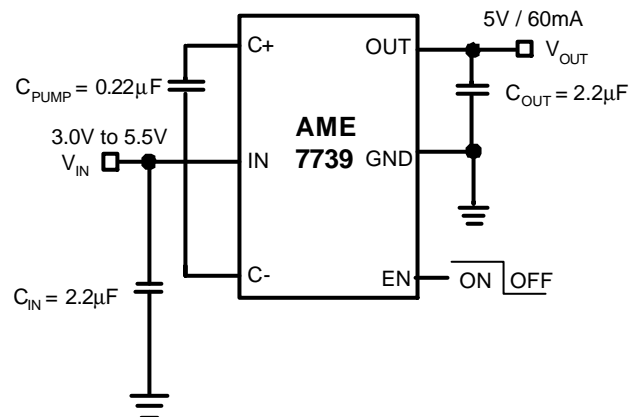

■ Pin Configuration

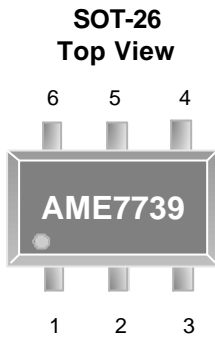

AME7739AEEY

1. OUT
2. GND
3. EN
4. C-
5. IN
6. C+

* Die Attach:
Conductive Epoxy

■ Pin Description

Pin Number	Pin Name	Description
1	OUT	Regulator Output Pin. V_{OUT} should be bypassed with a 2.2 μ F low ESR ceramic capacitor.
2	GND	Ground Pin Connection.
3	EN	Enable Input. Active Low disable the regulator.
4	C-	Pump Capacitor Negative Terminal.
5	IN	Input Supply Pin. V_{IN} should be bypassed with a 2.2 μ F low ESR ceramic capacitor.
6	C+	Pump Capacitor Positive Terminal.

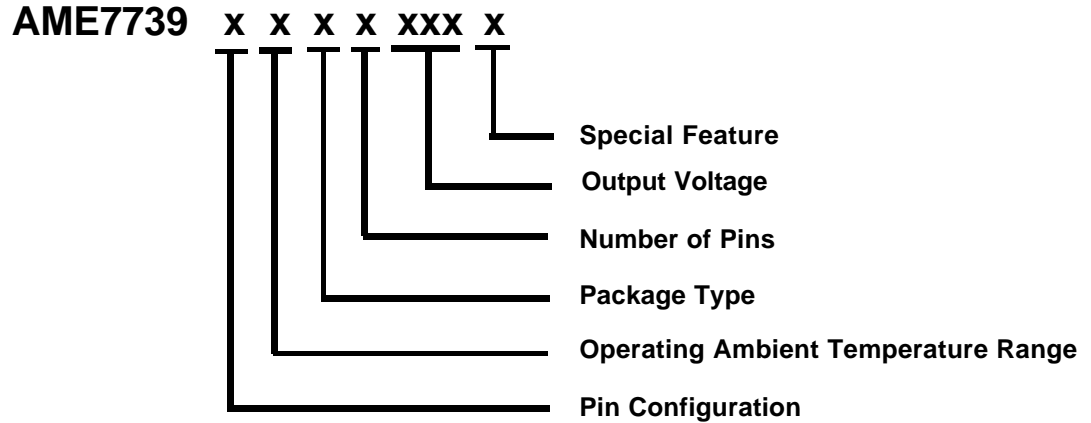
■ Ordering Information

Pin Configuration	Operating Ambient Temperature Range	Package Type	Number of Pins	Output Voltage	Special Feature
A 1. OUT (SOT-26) 2. GND 3. EN 4. C- 5. IN 6. C+	E: -40°C to +85°C	E: SOT-2X	Y: 6	330: V=3.3V 500: V=5V 550: V=5.5V	Z: Lead free

■ Ordering Information

Part Number	Marking*	Output Voltage	Package	Operating Ambient Temperature Range
AME7739AEEY330Z	BJFww	3.3V	SOT-26	- 40°C to +85°C
AME7739AEEY500Z	BENww	5V	SOT-26	- 40°C to +85°C
AME7739AEEY550Z	BDWww	5.5V	SOT-26	- 40°C to +85°C

Note: ww represents the date code and pls refer to Date Code Rule before Package Dimension.

* A line on top of the first letter represents lead free plating such as \bar{B} JFww.

Please consult AME sales office or authorized Rep./Distributor for the availability of package type.

■ Absolute Maximum Ratings

Parameter	Maximum	Unit
Input Voltage, Output Voltage, C-, C+	-0.3~+5.5	V
EN	-0.3~ $V_{IN} + 0.3$	
ESD Classification	B*	

Note: Caution: Stress above the listed absolute maximum rating may cause permanent damage to the device.

*HBM B:2000V~2999V

■ Recommended Operating Conditions

Parameter	Symbol	Rating	Unit
Ambient Temperature Range	T_A	- 40 to +85	°C
Junction Temperature Range	T_J	- 40 to +125	°C
Storage Temperature Range	T_{STG}	- 65 to +150	°C

■ Thermal Information

Parameter	Package	Die Attach	Symbol	Maximum	Unit
Thermal Resistance* (Junction to Case)	SOT-26	Conductive Epoxy	θ_{JC}	81	°C/W
Thermal Resistance (Junction to Ambient)			θ_{JA}	260	
Internal Power Dissipation			P_D	400	mW
Maximum Junction Temperature				150	°C
Solder Iron (10 Sec)**				350	°C

* Measure θ_{JC} on backside center of molding compound if IC has no tab.

** MIL-STD-202G 210F

■ Electrical Specifications (Contd.)

$T_A = -40^{\circ}\text{C}$ to 85°C , $V_{IN} = V_{OUT}/2 + 0.75\text{V}$, $I_{OUT} = 5\text{mA}$, $C_{IN} = 2.2\mu\text{F}$, $C_{OUT} = 2.2\mu\text{F}$, $C_{PUMP} = 0.22\mu\text{F}$, $V_{EN} = 1.3\text{V}$
 Typical Values are at $T_A = 25^{\circ}\text{C}$

Parameter	Symbol	Test Conditions	Min	Typ	Max	Units
Input Voltage	V_{IN}	$V_{OUT} = 5.5\text{V}$	3		5.5	V
		$V_{OUT} = 5\text{V}$	2.7		5.5	
		$V_{OUT} = \text{Others}$	1.8		5.5	
Output Voltage	V_{OUT}	$I_{OUT} \leq 60\text{mA}$, $3.3\text{V} < V_{IN} < 5.5\text{V}$	5.23	5.5	5.77	V
		$I_{OUT} \leq 15\text{mA}$, $2.7\text{V} < V_{IN} < 5.5\text{V}$	4.75	5	5.25	
		$I_{OUT} \leq 60\text{mA}$, $3.0\text{V} < V_{IN} < 5.5\text{V}$				
		$I_{OUT} \leq 15\text{mA}$, $1.8\text{V} < V_{IN} < 5.5\text{V}$	3.14	3.3	3.46	
		$I_{OUT} \leq 60\text{mA}$, $2.2\text{V} < V_{IN} < 5.5\text{V}$				
		$I_{OUT} \leq 15\text{mA}$, $1.8\text{V} < V_{IN} < 5.5\text{V}$	2.85	3	3.15	
		$I_{OUT} \leq 60\text{mA}$, $2.2\text{V} < V_{IN} < 5.5\text{V}$				
		$I_{OUT} \leq 15\text{mA}$, $1.8\text{V} < V_{IN} < 5.5\text{V}$	2.57	2.7	2.83	
		$I_{OUT} \leq 60\text{mA}$, $2.0\text{V} < V_{IN} < 5.5\text{V}$				
		$I_{OUT} \leq 15\text{mA}$, $1.8\text{V} < V_{IN} < 5.5\text{V}$	2.38	2.5	2.62	
		$I_{OUT} \leq 60\text{mA}$, $2.0\text{V} < V_{IN} < 5.5\text{V}$				
Quiescent Current	I_Q	$3\text{V} < V_{IN} < 5.5\text{V}$, $I_{OUT} = 0\text{mA}$, $V_{OUT} = 5.5\text{V}$		60	100	μA
		$2.7\text{V} < V_{IN} < 5.5\text{V}$, $I_{OUT} = 0\text{mA}$, $V_{OUT} = 5\text{V}$				
		$1.8\text{V} < V_{IN} < 5.5\text{V}$, $I_{OUT} = 0\text{mA}$, $V_{OUT} = \text{Others}$				
Shutdown Current	I_{SHDN}	$1.8\text{V} < V_{IN} < 5.5\text{V}$, $V_{EN} = \text{GND}$		0.01	1	
Output Current	I_{OUT}	$V_{OUT} = 5\text{V}$	60			mA
Short Circuit Current Limit	I_{SC}	$V_{OUT} = \text{GND}$		80		mA
Ripple Voltage (Note1)	V_{RIPPLE}	$V_{IN} = 3\text{V}$, $I_{OUT} = 60\text{mA}$, $V_{OUT} = 5\text{V}$		60		mVp-p
		$V_{IN} = 3.3\text{V}$, $I_{OUT} = 60\text{mA}$, $V_{OUT} = 5.5\text{V}$		70		
Efficiency	η	$I_{OUT} = 15\text{mA}$, $V_{IN} = 2.7\text{V}$, $V_{OUT} = 5\text{V}$		90		%
Frequency	f_{OSC}	Oscillator Free Running		1.0		MHz
EN Input Threshold High	V_{EH}		1.3			V
EN Input Threshold Low	V_{EL}				0.6	V
EN Input Current	I_{EN}	$V_{EN} = V_{IN}$, $V_{EN} = \text{GND}$			0.1	μA
Over Temperature Shutdown	OTS			160		$^{\circ}\text{C}$
Over Temperature Hysteresis	OTH			20		

Note 1: Effective series resistance (ESR) of capacitors is $< 0.1\Omega$.

■ Detailed Description

The AME7739 regulated charge pump provides a regulated input voltages ranging from less than the output to greater than the input. This is accomplished by automatic mode switching within the device.

■ Short Circuit and Thermal Protection

The AME7739 has a thermal protection and shutdown circuit that continuously monitors the IC junction temperature. If the thermal protection circuit senses the die temperature exceeding approximately 160°C, the thermal shutdown will disable the charge pump switching cycle operation, The thermal limit system has 20°C of system hysteresis before the charge pump can reset. Once the over current event is removed from the output and the junction temperature drops below 140°C, the charge pump will the become active again. The thermal protection system will cycle on and off if an output short circuit condition persists. This will allow the AME7739 to operate indefinitely a short circuit condition without damage to the device.

■ Shutdown Mode

A control pin EN on the regulator can be used to place the device into an energy-saving shutdown mode. In this mode, the output is disconnected from the input as long as V_{IN} is greater than or equal to minimum V_{IN} and input quiescent current is reduced to 1μA maximum.

■ Capacitor Selection

For minimum output voltage ripple, the output capacitor C_{OUT} should be a ceramic, surface-mount type. Tantalum capacitors generally have a higher Effective Series Resistance (ESR) and may contribute to higher output voltage ripple. Leaded capacitors also increase ripple due to the higher inductance of the package itself. To achieve best operation with low input voltage and high load current, the input and pump capacitors (C_{IN} , C_{PUMP} respectively) should also be surface-mount ceramic types. In all cases, X7R dielectric is recommended.

With light loads or higher input voltage, a smaller 0.1μF pump capacitor (C_{PUMP}) and smaller 1μF input and output capacitor (C_{IN} and C_{OUT} , respectively) can be used. To minimize output voltage ripple, increase the output capacitor, C_{OUT} , to 10μF or larger.

■ Efficiency

The efficiency of the charge pump regulator varies with the output voltage version, the applied input voltage, the load current, and the internal operation mode of the device.

The approximate efficiency is given by:

$$\text{5.5V, 5V Version } (V_{IN} \leq V_{OUT}) \\ \text{Efficiency (\%)} = V_{OUT} / 2V_{IN} \cdot 100\%$$

$$\text{Others Version } (V_{IN} > V_{OUT}) \\ \text{Efficiency (\%)} = V_{OUT} / V_{IN} \cdot 100\%$$

■ Layout

Large ripple currents flow in the V_{IN} and V_{OUT} traces. To minimized both input and output ripple, keep the capacitors as close as possible to the regulator using short, direct circuit traces.

The trace lengths from the input and output capacitors have been kept as short as possible. A star ground system has been implemented, with GND pin as the center of the star. No ground plane is provided in other layers, as this will provide capacitive coupling for noise spikes.

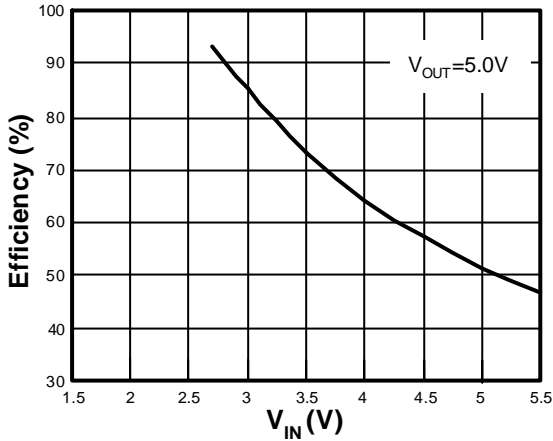
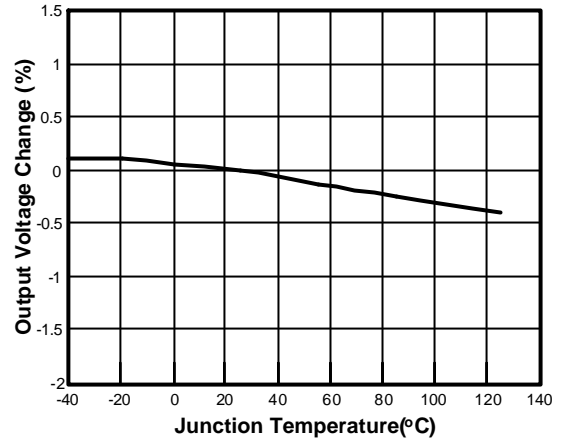
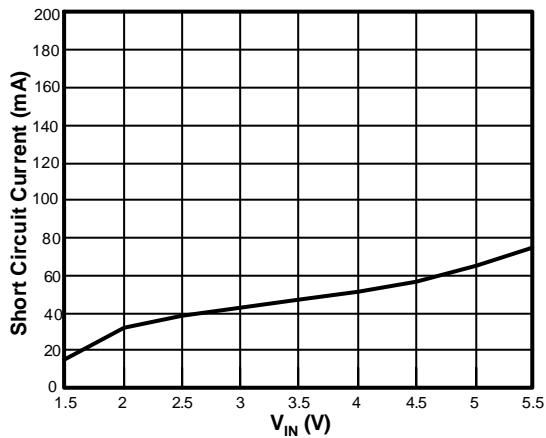
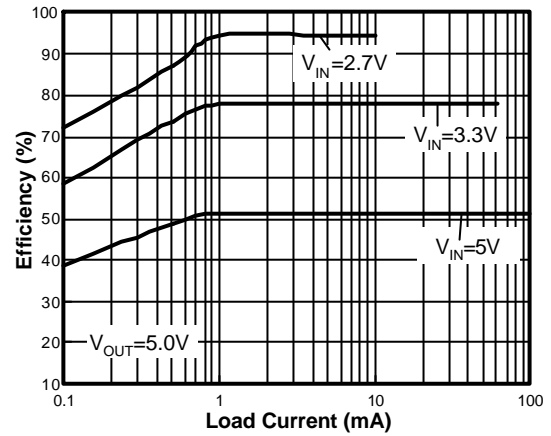
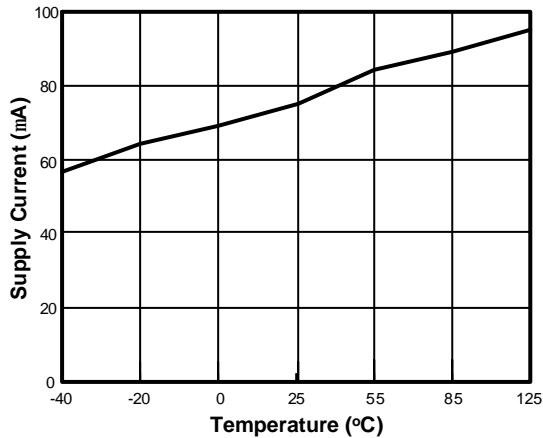
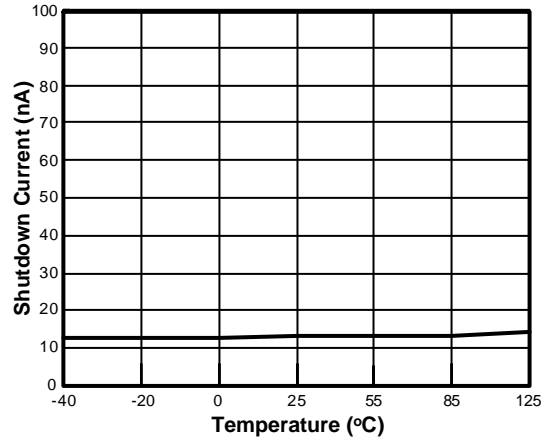
Efficiency vs V_{IN}

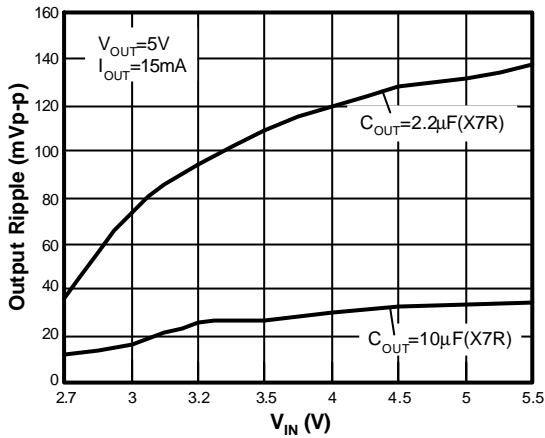
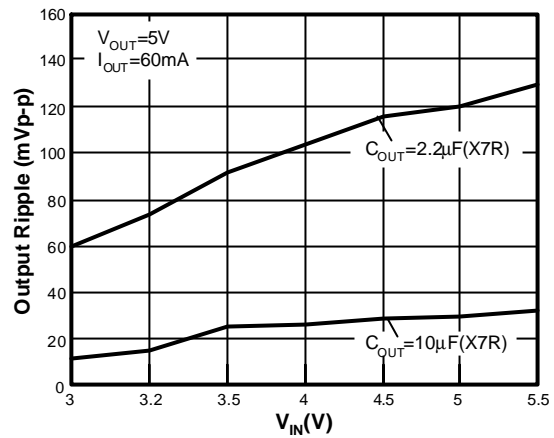
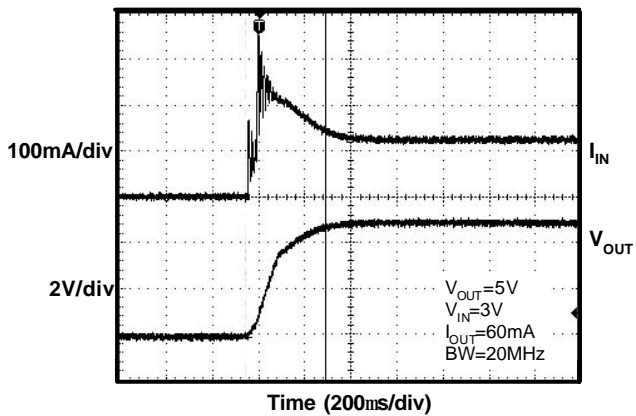
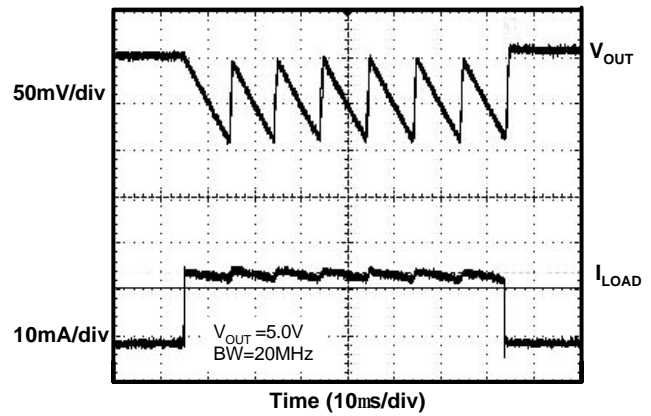
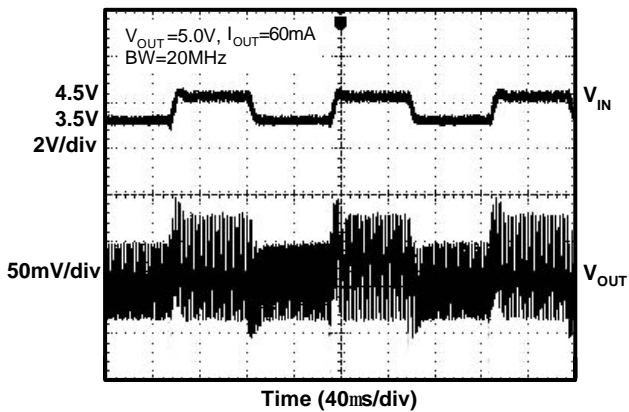
Output Voltage vs Temperature

Short Circuit Current vs V_{IN}

Efficiency vs Load Current

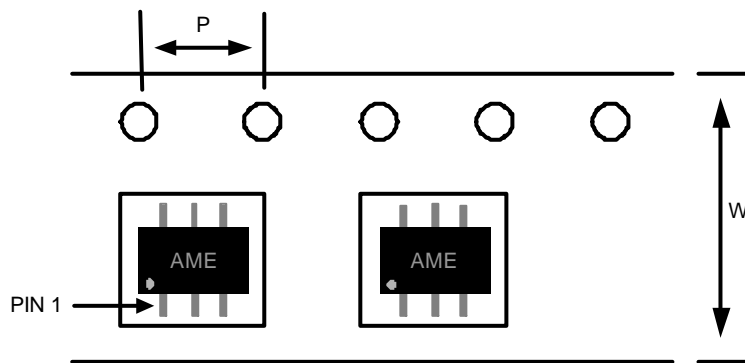
**Supply Current vs Temperature
(No Load)**

Shutdown Current vs Temperature

Output Ripple Voltage vs V_{IN}

Output Ripple Voltage vs V_{IN}

Input Current at Turn-On

Load Transient Response

Line Transient Response

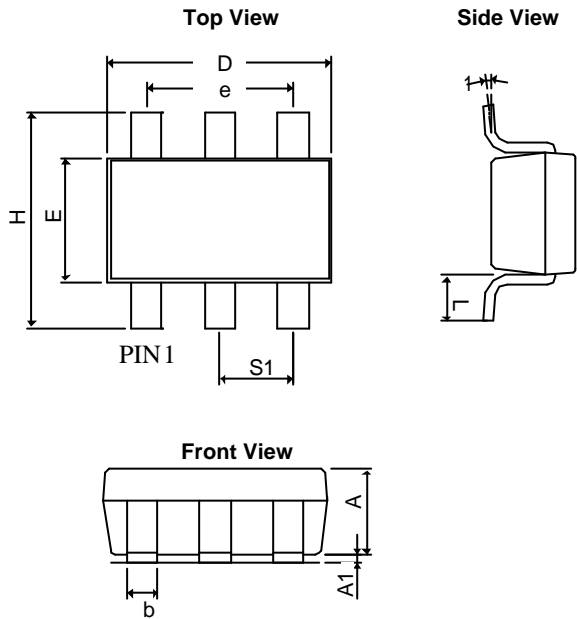
■ Date Code Rule

Marking			Date Code		Year
A	A	A	W	W	xxx0
A	A	A	W	<u>W</u>	xxx1
A	A	A	<u>W</u>	W	xxx2
A	A	A	<u>W</u>	<u>W</u>	xxx3
A	A	<u>A</u>	W	W	xxx4
A	A	<u>A</u>	W	<u>W</u>	xxx5
A	A	<u>A</u>	<u>W</u>	W	xxx6
A	A	<u>A</u>	<u>W</u>	<u>W</u>	xxx7
A	<u>A</u>	A	W	W	xxx8
A	<u>A</u>	A	W	<u>W</u>	xxx9

■ Tape & Reel Dimension
SOT-26

Carrier Tape, Number of Components Per Reel and Reel Size

Package	Carrier Width (W)	Pitch (P)	Part Per Full Reel	Reel Size
SOT-26	8.0±0.1 mm	4.0±0.1 mm	3000pcs	180±1 mm

■ Package Dimension
SOT-26

SYMBOLS	MILLIMETERS		INCHES	
	MIN	MAX	MIN	MAX
A	1.20REF		0.0472REF	
A₁	0.00	0.15	0.0000	0.0059
b	0.30	0.55	0.0118	0.0217
D	2.70	3.10	0.1063	0.1220
E	1.40	1.80	0.0551	0.0709
e	1.90 BSC		0.0748 BSC	
H	2.60	3.00	0.10236	0.11811
L	0.37REF		0.0146REF	
q1	0°	10°	0°	10°
S₁	0.95REF		0.0374REF	



www.ame.com.tw
E-Mail: sales@ame.com.tw

Life Support Policy:

These products of AME, Inc. are not authorized for use as critical components in life-support devices or systems, without the express written approval of the president of AME, Inc.

AME, Inc. reserves the right to make changes in the circuitry and specifications of its devices and advises its customers to obtain the latest version of relevant information.

© AME, Inc. , November 2008
Document: 1033-DS7739-A.04

Corporate Headquarter
AME, Inc.

2F, 302 Rui-Guang Road, Nei-Hu District
Taipei 114, Taiwan, R.O.C.
Tel: 886 2 2627-8687
Fax: 886 2 2659-2989