

■ General Description

The AME8501 family allows the user to customize the CPU reset function without any external components. The user has a large choice of reset voltage thresholds, reset time intervals, and output driver configurations, all of which are preset at the factory. Each wafer is trimmed to the customer specifications.

These circuits monitor the power supply voltage of μP based systems. When the power supply voltage drops below the voltage threshold a reset is asserted immediately (within an interval T_{D1}). The reset remains asserted after the supply voltage rises above the voltage threshold for a time interval, T_{D2} . The reset output may be either active high (RESET) or active low (RESETB). The reset output may be configured as open drain. The state of the reset output is guaranteed to be correct for supply voltages greater than 0.9V.

■ Features

- Internally Fixed Threshold 1.2V to 4.5V in 0.1V Step
- High Accuracy $\pm 1.5\%$
- Low Supply Current 3μA
- No External Components Required
- Quick Reset within 20μs
- Built-in Recovery Delay Include 0ms, 55ms, 220ms, 450ms
- Low Functional Supply Voltage 0.9V
- N-Channel Open-Drain Output
- Small SOT-23, TSOT-23A, SOT-143, SC-70-4, SOT-25 and TSOT-25A Package
- RoHS Compliant and Halogen Free

■ Application

- Portable Electronics
- Power Supplies
- Computer Peripherals
- Data Acquisition Systems
- Applications using CPUs
- Consumer Electronics

■ Typical Application

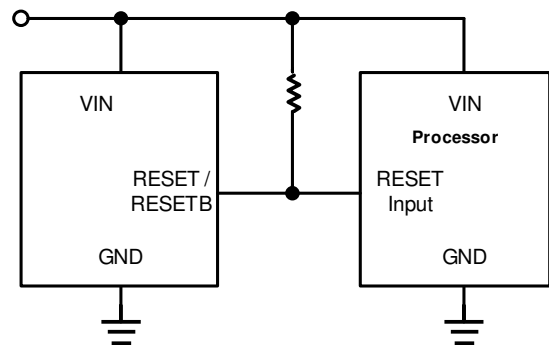

■ Functional Block Diagram

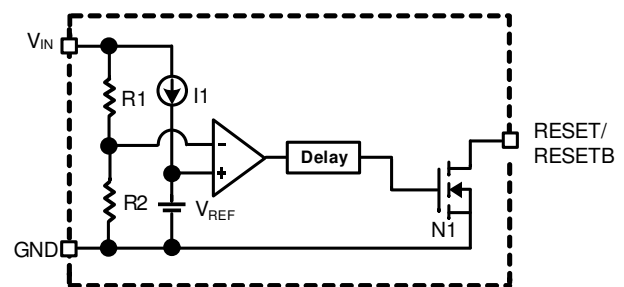

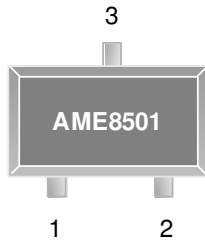
■ Pin Configuration
**SOT-23/TSOT-23A
Top View**

AME8501-AETxxxxxx

1. GND
2. RESET/RESETB
3. IN

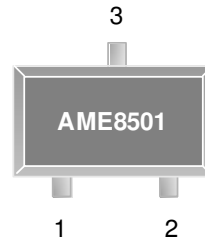
*** Die Attach:
Non-Conductive Epoxy**

**SOT-23/TSOT-23A
Top View**

AME8501-BETxxxxxx

1. RESET/RESETB
2. GND
3. IN

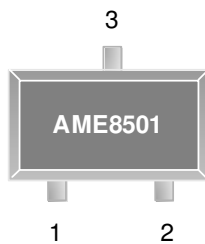
*** Die Attach:
Non-Conductive Epoxy**

**SOT-23/TSOT-23A
Top View**

AME8501-CETxxxxxx

1. RESET/RESETB
2. IN
3. GND

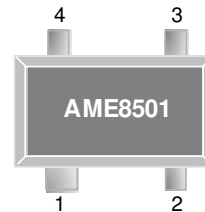
*** Die Attach:
Conductive Epoxy**

**SOT-143
Top View**

AME8501-A4Uxxxxxx

1. GND
2. RESET/RESETB
3. NC
4. IN

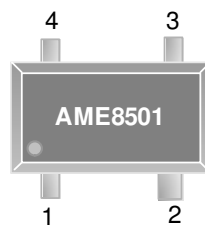
*** Die Attach:
Conductive Epoxy**

**SC-70-4
Top View**

AME8501-AIUxxxxxx

1. GND
2. RESET/RESETB
3. NC
4. IN

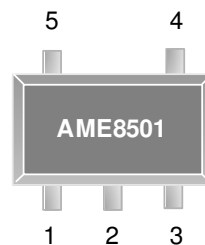
*** Die Attach:
Non-Conductive Epoxy**

**SOT-25/TSOT-25A
Top View**

AME8501-AEVxxxxxx

1. RESET/RESETB
2. IN
3. GND
4. NC
5. NC

*** Die Attach:
Non-Conductive Epoxy**

■ Pin Description

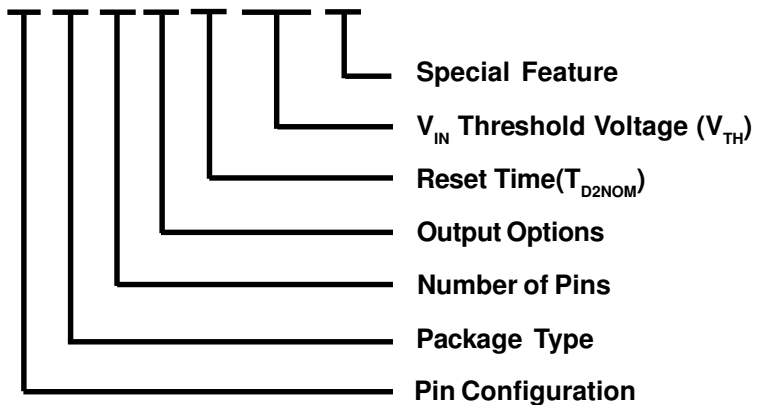
Pin No.						Pin Name	Pin Description
SOT-23 / TSOT-23A			SOT-143	SC-70-4	SOT-25 / TSOT-25A		
A	B	C					
1	2	3	1	1	3	GND	Ground.
2	1	1	2	2	1	RESET/ RESETB	This pin can be ordered as RESET or RESETB. Reset is active high. RESETB is active low. It is also available with an open-drain.
3	3	2	4	4	2	IN	Positive power supply. A reset is asserted after this voltage drops below a predetermined level. After V_{IN} rises above that level the reset output remains asserted until the end of the reset timeout period.
N/A	N/A	N/A	3	3	4, 5	NC	No connection. Not internally connected. Can left floating or connected to GND.

■ Ordering Information
AME8501 - x x x x x xxx x

Pin Configuration	Package Type	Number of Pins	Output Options	Reset Time (T_{D2NOM})	V_{IN} Threshold Voltage (V_{TH})	Special Feature
A 1. GND <small>(SOT-23)</small> 2. RESET/RESETB <small>(TSOT-23A)</small> 3. IN	E: SOT-2X I: SC-70 4: SOT-143	T: 3 U: 4 V: 5	A: RESETB B: RESET	B: 0ms C: 55ms D: 220ms G: 450ms	120: 1.2V 130: 1.3V 140: 1.4V : : : : : : 480: 4.8V 490: 4.9V 500: 5.0V	N/A: SOT-23/SOT-25 K: 0.9mm max (for TSOT-2XA Only)
B 1. RESET/RESETB <small>(SOT-23)</small> 2. GND <small>(TSOT-23A)</small> 3. IN						
C 1. RESET/RESETB <small>(SOT-23)</small> 2. IN <small>(TSOT-23A)</small> 3. GND						
A 1. GND <small>(SOT-143)</small> 2. RESET/RESETB 3. NC 4. IN						
A 1. RESET/RESETB <small>(SOT-25)</small> 2. IN <small>(TSOT-25A)</small> 3. GND 4. NC 5. NC						
A 1. GND <small>(SC-70-4)</small> 2. RESET/RESETB 3. NC 4. IN						

AME

AME8501

μProcessor Supervisory

■ Absolute Maximum Ratings

Parameter		Maximum	Unit
Supply Voltage		6	V
Input Current, V_{IN}		20	mA
Output Current, RESET, RESETB		20	mA
ESD Classification	HBM	2	kV
	MM	200	V

■ Recommended Operating Conditions

Parameter	Symbol	Rating	Unit
Junction Temperature Range	T_J	-40 to +125	°C
Ambient Temperature Range	T_A	-40 to +85	
Storage Temperature Range	T_{STG}	-65 to +150	

■ Thermal Information

Parameter	Package	Die Attach	Symbol	Maximum	Unit
Thermal Resistance* (Junction to Case)	SOT-23 TSOT-23A	Conductive Epoxy	θ_{JC}	81	°C / W
	SOT-143			130	
	SOT-23 SOT-25	Non-Conductive Epoxy		140	
	TSOT-23A TSOT-25A			130	
	SC-70-4			120	
Thermal Resistance (Junction to Ambient)	SOT-23	Conductive Epoxy	θ_{JA}	260	°C / W
	TSOT-23A			230	
	SOT-143			350	
	SOT-23 SOT-25	Non-Conductive Epoxy		280	
	TSTO-23A TSOT-25A			250	
	SC-70-4			400	
Internal Power Dissipation	SOT-23	Conductive Epoxy	P_D	400	mW
	TSOT-23A			455	
	SOT-143			285	
	SOT-23 SOT-25	Non-Conductive Epoxy		400	
	TSTO-23A TSOT-25A			400	
	SC-70-4			300	
Lead Temperature (soldering 10 sec)**				260	°C

* Measure θ_{JC} on backside center of molding compound if IC has no tab.

** MIL-STD-202G210F

■ Electrical Specifications
 $T_A=27^\circ\text{C}$, unless otherwise specified.

Parameter		Symbol	Test Condition	Min	Typ	Max	Units
Operating $V_{DD}(V_{OUT})$ Range	V_{DD}	$\overline{\text{RESET}}$		0.9		6	V
		RESET		1.1		6	
Supply Current	I_{DD}		$V_{DD}=5\text{V}, T_A=27^\circ\text{C}$		3	8	μA
Reset Threshold	V_{TH}		$T_A=27^\circ\text{C}$		1.2 to 4.5		V
Threshold Voltage Accuracy	ΔV_{TH}		$T_A=27^\circ\text{C}$	-1.5		1.5	%
V_{DD} Drop to Reset Delay	t_{RD}		Drop= $V_{TH}-125\text{mV}$		20		μs
Reset Active Time Out Period	Version B	t_{RP}	$V_{DD} \geq 1.02 \times V_{TH}$	0	0	0	ms
	Version C			35	55	75	
	Version D			143	220	297	
	Version G			292	450	608	
RESET Output Voltage Low	V_{OL}		$V_{DD} > V_{TH(\text{MAX})}, I_{\text{SINK}}=3.5\text{mA}, V_{TH} \geq 3\text{V}$			0.4	V
			$V_{DD} > V_{TH(\text{MAX})}, I_{\text{SINK}}=1.2\text{mA}, V_{TH} \geq 1.8\text{V}$			0.3	
			$V_{DD} > V_{TH(\text{MAX})}, I_{\text{SINK}}=0.5\text{mA}, V_{TH} \geq 1.2\text{V}$			0.3	
$\overline{\text{RESET}}$ Output Voltage Low	V_{OL}		$V_{DD} < V_{TH(\text{MIN})}, I_{\text{SINK}}=3.5\text{mA}, V_{TH} \geq 3\text{V}$			0.4	V
			$V_{DD} < V_{TH(\text{MIN})}, I_{\text{SINK}}=1.2\text{mA}, V_{TH} \geq 1.8\text{V}$			0.3	
			$V_{TH(\text{MIN})} > V_{DD} > 1\text{V}, I_{\text{SINK}}=0.5\text{mA}$			0.3	
Hysteresis Width	V_{HYS}				$0.01V_{TH}$		V

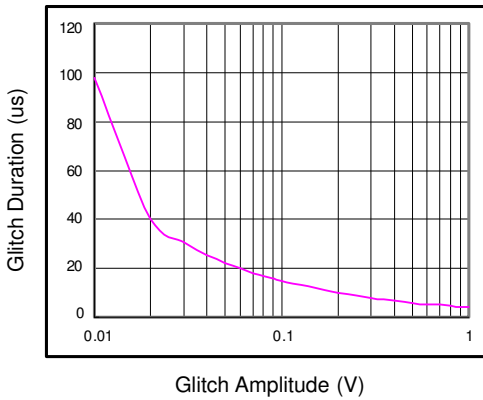
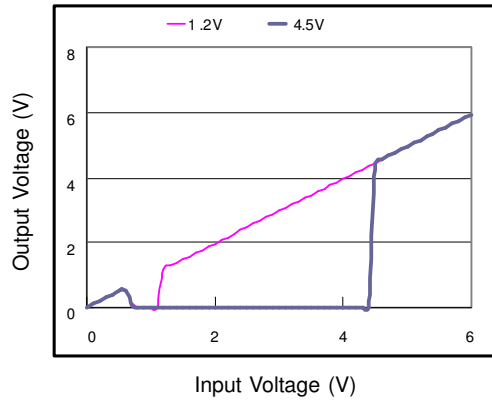
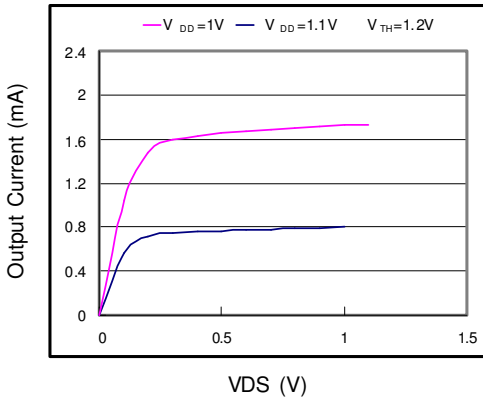
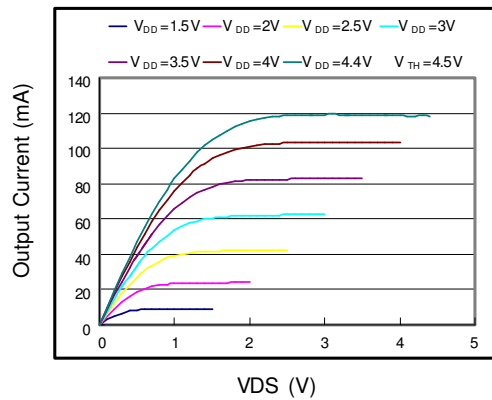
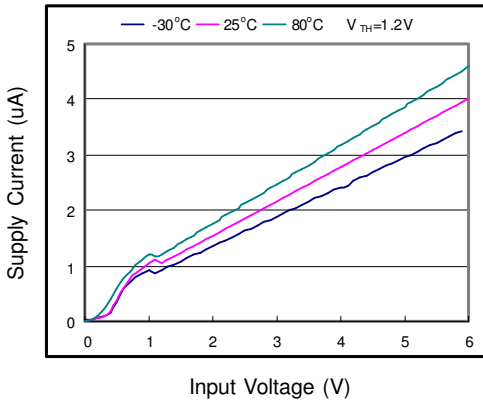
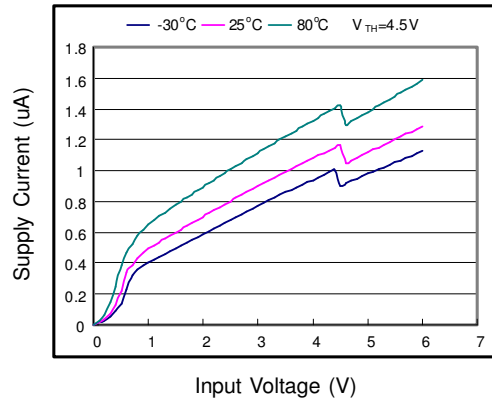
■ Characterization Curve
Glitch Rejection

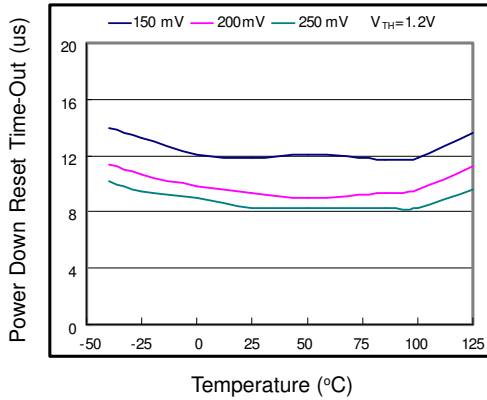
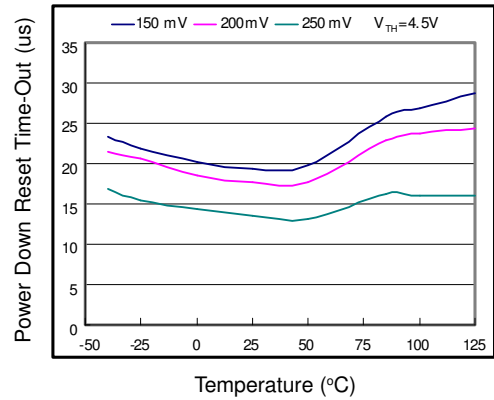
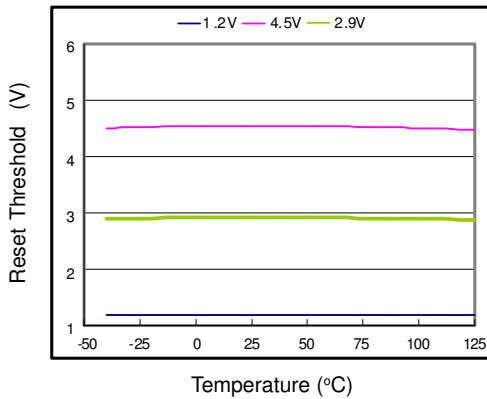
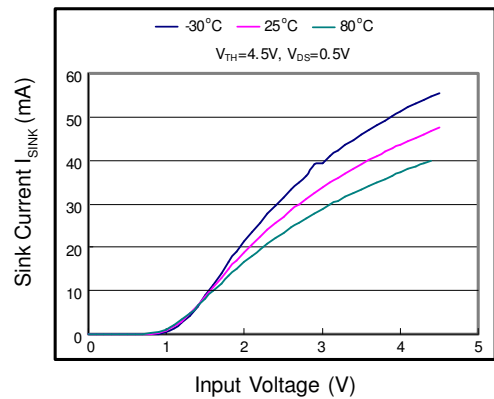
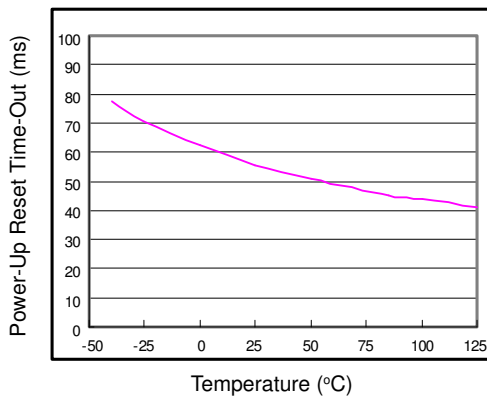
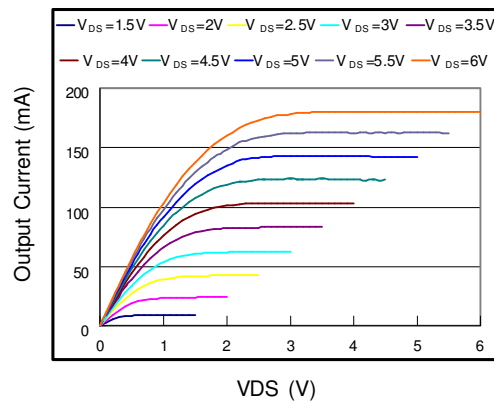
Output Voltage vs. Input Voltage

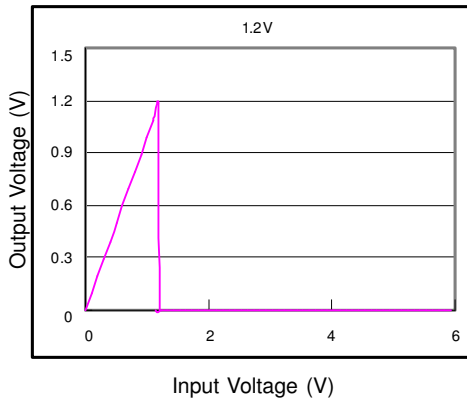
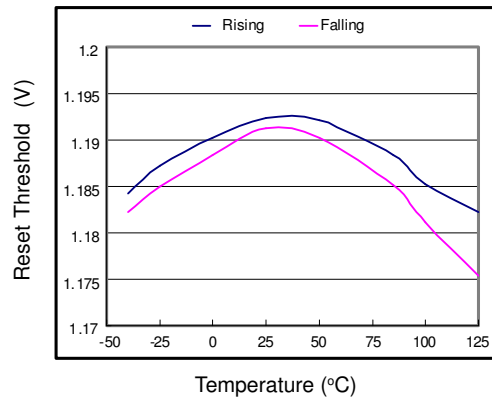
Nch Driver Output Current vs VDS

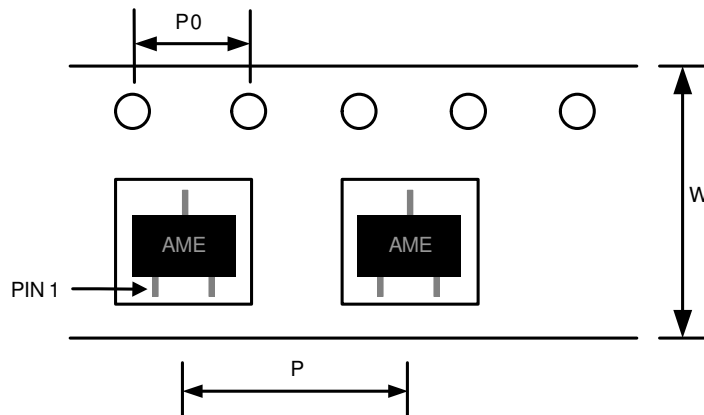
Nch Driver Output Current vs VDS

Supply Current vs Input Voltage

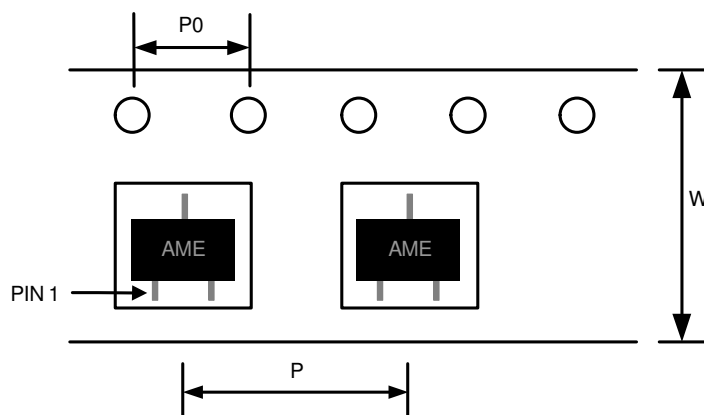
Supply Current vs Input Voltage

■ Characterization Curve (Contd.)
Power-Down Reset vs. Temperature

Power-Down Reset vs. Temperature

Reset Threshold Derivation vs. Temperature

Nch Driver Sink Current vs. Input Voltage

Power-Up Reset Time-Out vs. Temperature

Nch Driver Output Current vs VDS

■ Characterization Curve (Contd.)
Output Voltage vs. Input Voltage

Threshold Voltage vs. Temperature

■ Tape and Reel Dimension
SOT-23

Carrier Tape, Number of Components Per Reel and Reel Size

Package	Carrier Width (W)	Pitch (P)	Pitch (P0)	Part Per Full Reel	Reel Size
SOT-23	8.0±0.1 mm	4.0±0.1 mm	4.0±0.1 mm	3000pcs	180±1 mm

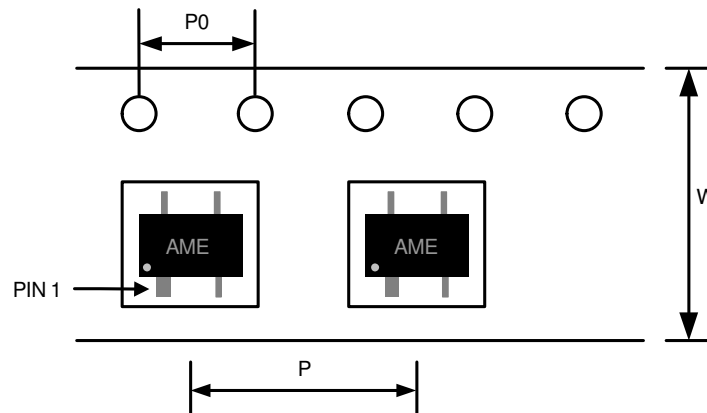
TSOT-23-A

Carrier Tape, Number of Components Per Reel and Reel Size

Package	Carrier Width (W)	Pitch (P)	Pitch (P0)	Part Per Full Reel	Reel Size
TSOT-23A	8.0±0.1 mm	4.0±0.1 mm	4.0±0.1 mm	3000pcs	180±1 mm

■ Tape and Reel Dimension (Contd.)
SOT-143

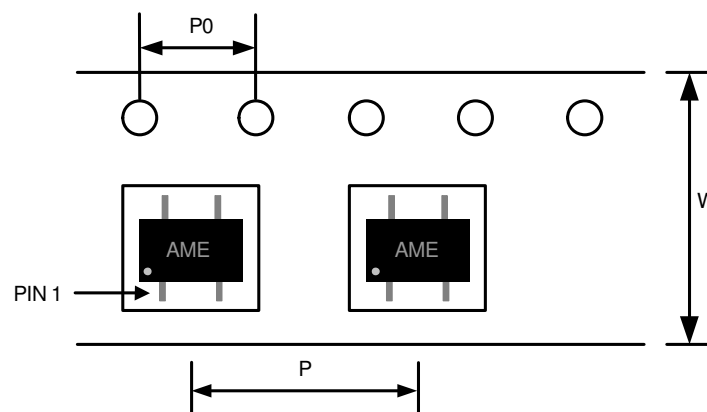
Carrier Tape, Number of Components Per Reel and Reel Size

Package	Carrier Width (W)	Pitch (P)	Pitch (P0)	Part Per Full Reel	Reel Size
SOT-143	8.0±0.1 mm	4.0±0.1 mm	4.0±0.1 mm	3000pcs	180±1 mm

SC-70-4

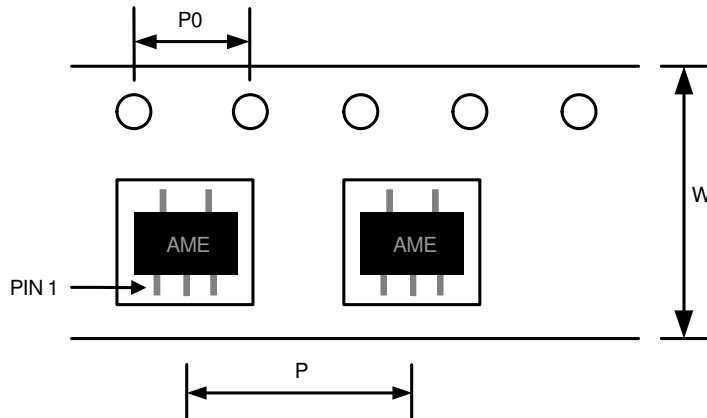
Carrier Tape, Number of Components Per Reel and Reel Size

Package	Carrier Width (W)	Pitch (P)	Pitch (P0)	Part Per Full Reel	Reel Size
SC-70-4	8.0±0.1 mm	4.0±0.1 mm	4.0±0.1 mm	3000pcs	180±1 mm

■ Tape and Reel Dimension (Contd.)
SOT-25

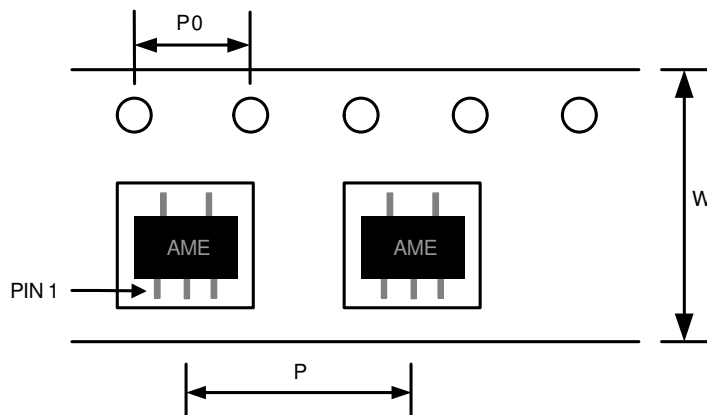
Carrier Tape, Number of Components Per Reel and Reel Size

Package	Carrier Width (W)	Pitch (P)	Pitch (P0)	Part Per Full Reel	Reel Size
SOT-25	8.0±0.1 mm	4.0±0.1 mm	4.0±0.1 mm	3000pcs	180±1 mm

TSOT-25A

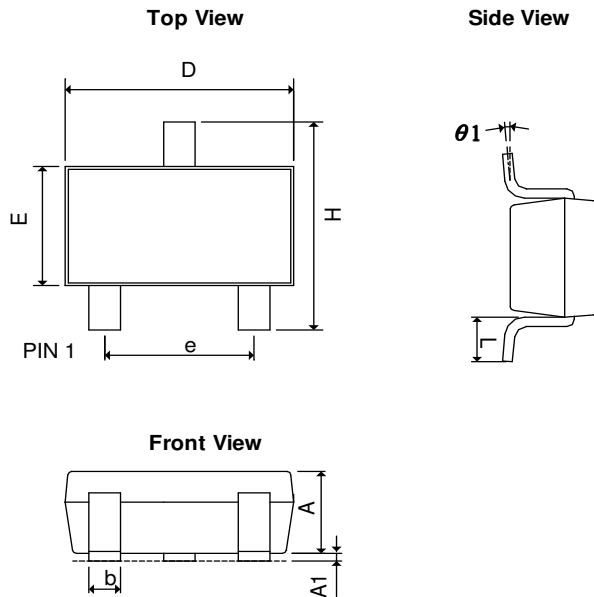
Carrier Tape, Number of Components Per Reel and Reel Size

Package	Carrier Width (W)	Pitch (P)	Pitch (P0)	Part Per Full Reel	Reel Size
TSOT-25A	8.0±0.1 mm	4.0±0.1 mm	4.0±0.1 mm	3000pcs	180±1 mm

■ Package Dimension
SOT-23

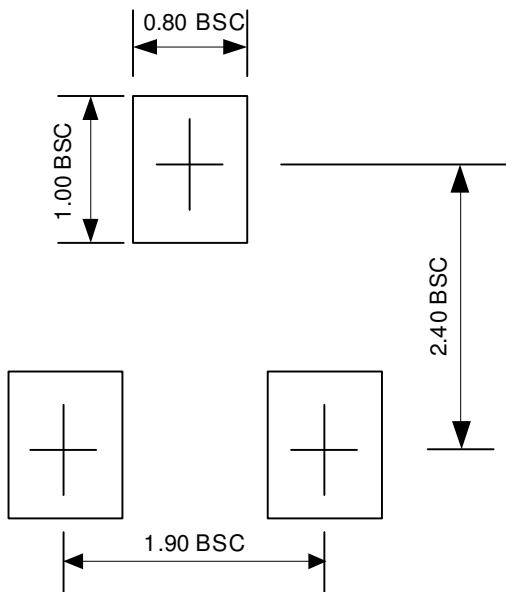
SYMBOLS	MILLIMETERS		INCHES	
	MIN	MAX	MIN	MAX
A	0.90	1.40	0.0354	0.0551
A ₁	0.00	0.15	0.0000	0.0059
b	0.30	0.50	0.0118	0.0197
D	2.70	3.10	0.1063	0.1220
E	1.40	1.80	0.0551	0.0709
e	1.90 BSC		0.0748 BSC	
H	2.40	3.00	0.0945	0.1181
L	0.35BSC		0.0138 BSC	
$\theta 1$	0°	10°	0°	10°

■ Lead Pattern Drawing

Note:

1. Lead pattern unit description:

BSC: Basic. Represents theoretical exact dimension or dimension target.

2. Dimensions in Millimeters.

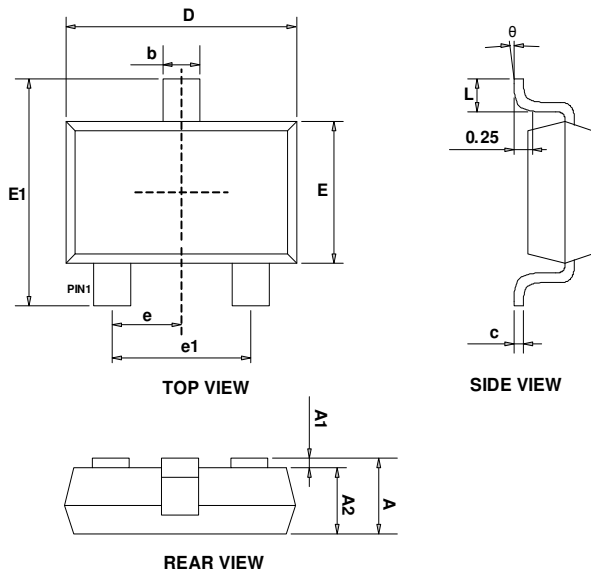
3. General tolerance $\pm 0.05\text{mm}$ unless otherwise specified.

■ Package Dimension (Contd.)
TSOT-23A

SYMBOLS	MILLIMETERS		INCHES	
	MIN	MAX	MIN	MAX
A	0.700	0.900	0.028	0.035
A1	0.000	0.100	0.000	0.004
A2	0.700	0.800	0.028	0.031
b	0.350	0.500	0.014	0.020
c	0.080	0.200	0.003	0.008
D	2.820	3.020	0.111	0.119
E	1.600	1.700	0.063	0.067
E1	2.650	2.950	0.104	0.116
e	0.95 BSC		0.037 BSC	
e1	1.90 BSC		0.075 BSC	
L	0.300	0.600	0.012	0.024
θ	0°	8°	0°	8°

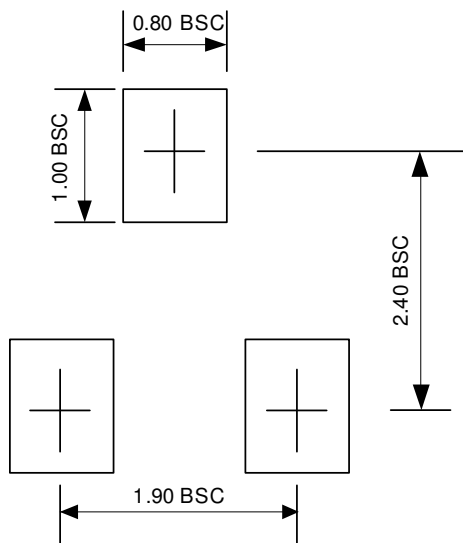
■ Lead Pattern Drawing

Note:
1. Lead pattern unit description:

BSC: Basic. Represents theoretical exact dimension or dimension target.

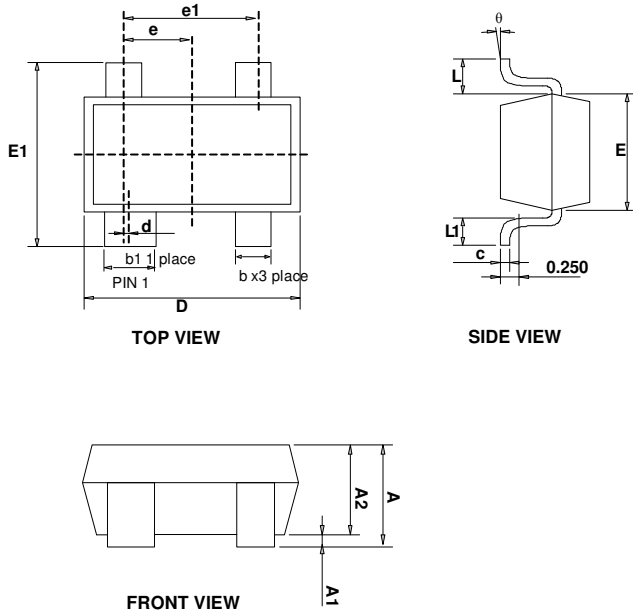
2. Dimensions in Millimeters.
3. General tolerance $\pm 0.05\text{mm}$ unless otherwise specified.

■ Package Dimension (Contd.)
SOT-143

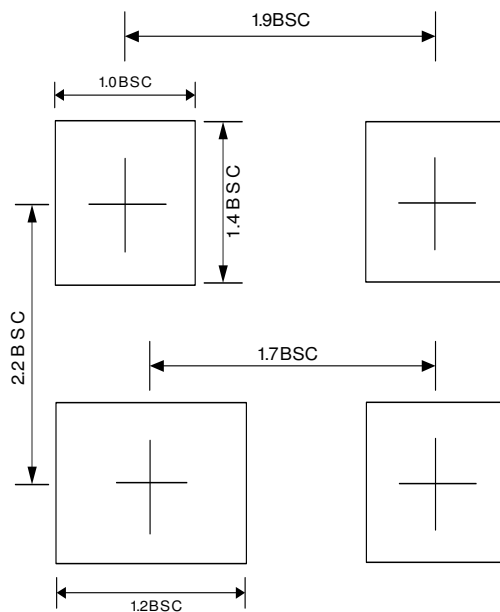
SYMBOLS	MILLIMETERS		INCHES	
	MIN	MAX	MIN	MAX
A	0.900	1.150	0.035	0.045
A1	0.000	0.100	0.000	0.004
A2	0.900	1.050	0.035	0.041
b	0.300	0.500	0.012	0.020
b1	0.750	0.900	0.030	0.035
c	0.080	0.150	0.003	0.006
D	2.800	3.000	0.110	0.118
d	0.200 TYP		0.008 TYP	
E	1.200	1.400	0.047	0.055
E1	2.250	2.550	0.089	0.100
e	0.950 TYP		0.037 TYP	
e1	1.800	2.000	0.071	0.079
L	0.550 REF.		0.022 REF	
L1	0.300	0.500	0.012	0.020
θ	0°	8°	0°	8°

■ Lead Pattern Drawing

Note:
1. Lead pattern unit description:

BSC: Basic. Represents theoretical exact dimension or dimension target.

2. Dimensions in Millimeters.

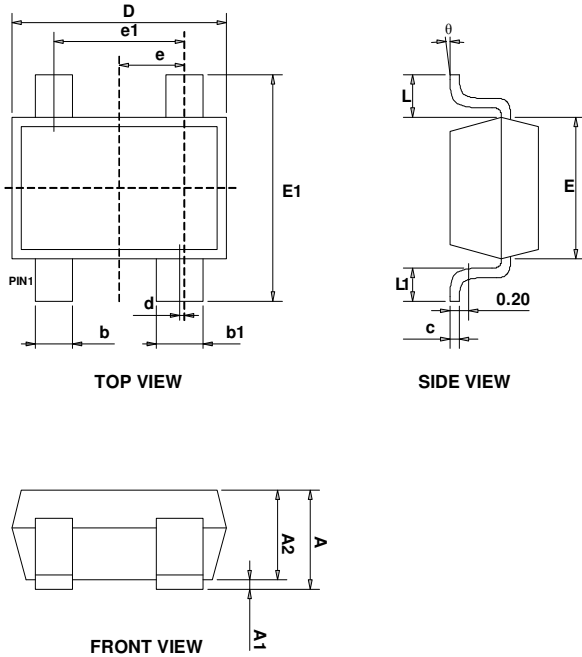
3. General tolerance 0.05mm unless otherwise specified.

■ Package Dimension (Contd.)
SC-70-4

SYMBOLS	MILLIMETERS		INCHES	
	MIN	MAX	MIN	MAX
A	0.900	1.100	0.035	0.043
A1	0.000	0.100	0.000	0.004
A2	0.900	1.000	0.035	0.039
b	0.250	0.400	0.010	0.016
b1	0.350	0.500	0.014	0.020
c	0.080	0.150	0.003	0.006
d	0.050 TYP		0.002 TYP	
D	2.000	2.200	0.079	0.087
E	1.150	1.350	0.045	0.053
E1	2.150	2.450	0.085	0.096
e	0.650 TYP		0.026 TYP	
e1	1.200	1.400	0.047	0.055
L	0.525 REF		0.021 REF	
L1	0.260	0.460	0.010	0.018
θ	0°	8°	0°	8°

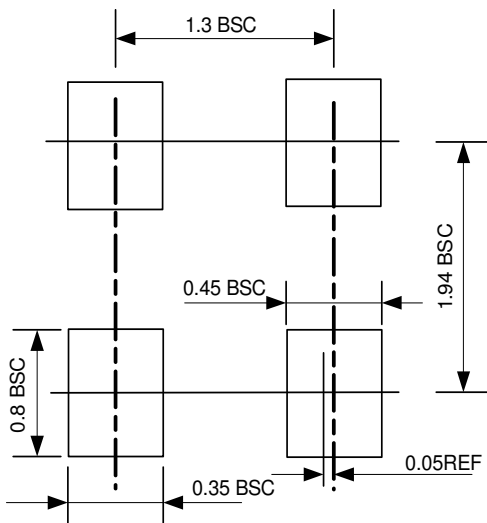
■ Lead Pattern Drawing

Note:

1. Lead pattern unit description:

BSC: Basic. Represents theoretical exact dimension or dimension target.

2. Dimensions in Millimeters.

3. General tolerance $\pm 0.05\text{mm}$ unless otherwise specified.

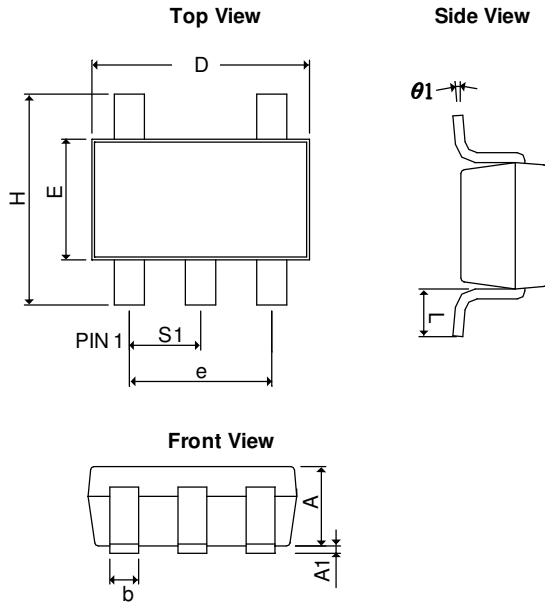
■ Package Dimension (Contd.)
SOT-25

SYMBOLS	MILLIMETERS		INCHES	
	MIN	MAX	MIN	MAX
A	0.90	1.30	0.0354	0.0512
A ₁	0.00	0.15	0.0000	0.0059
b	0.30	0.55	0.0118	0.0217
D	2.70	3.10	0.1063	0.1220
E	1.40	1.80	0.0551	0.0709
e	1.90 BSC		0.0748 BSC	
H	2.60	3.00	0.1024	0.1181
L	0.37 BSC		0.0146 BSC	
θ ₁	0°	10°	0°	10°
S ₁	0.95 BSC		0.0374 BSC	

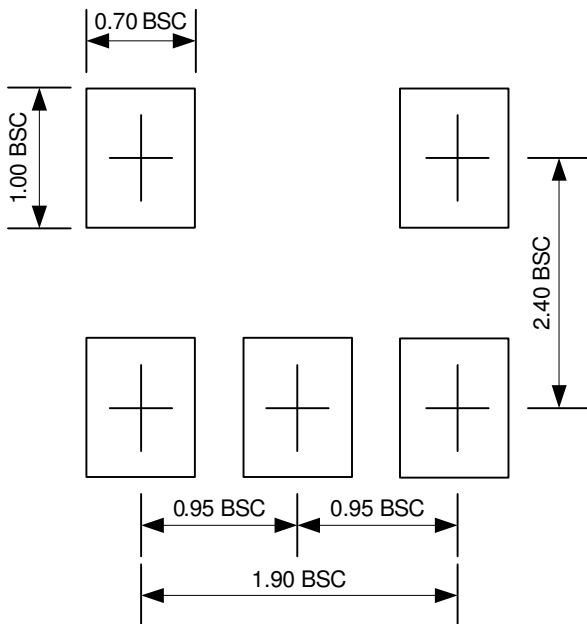
■ Lead Pattern Drawing

Note:

1. Lead pattern unit description:

BSC: Basic. Represents theoretical exact dimension or dimension target.

2. Dimensions in Millimeters.

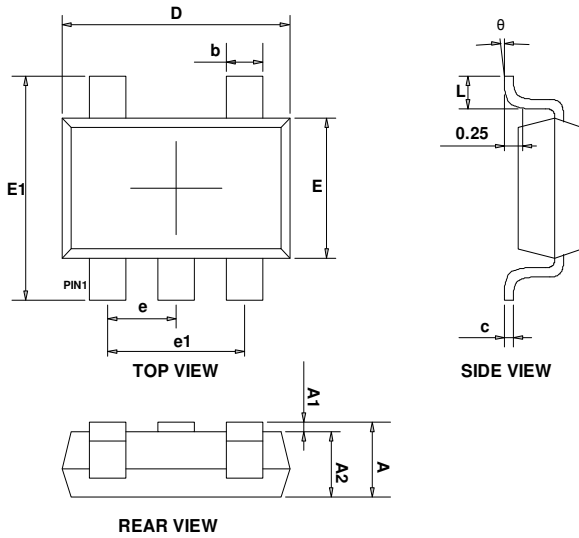
3. General tolerance $\pm 0.05\text{mm}$ unless otherwise specified.

■ Package Dimension (Contd.)
TSOT-25A

SYMBOLS	MILLIMETERS		INCHES	
	MIN	MAX	MIN	MAX
A	0.700	0.900	0.028	0.035
A1	0.000	0.100	0.000	0.004
A2	0.700	0.800	0.028	0.031
b	0.350	0.500	0.014	0.020
c	0.080	0.200	0.003	0.008
D	2.820	3.020	0.111	0.119
E	1.600	1.700	0.063	0.067
E1	2.650	2.950	0.104	0.116
e	0.95 BSC		0.037 BSC	
e1	1.90 BSC		0.075 BSC	
L	0.300	0.600	0.012	0.024
θ	0°	8°	0°	8°

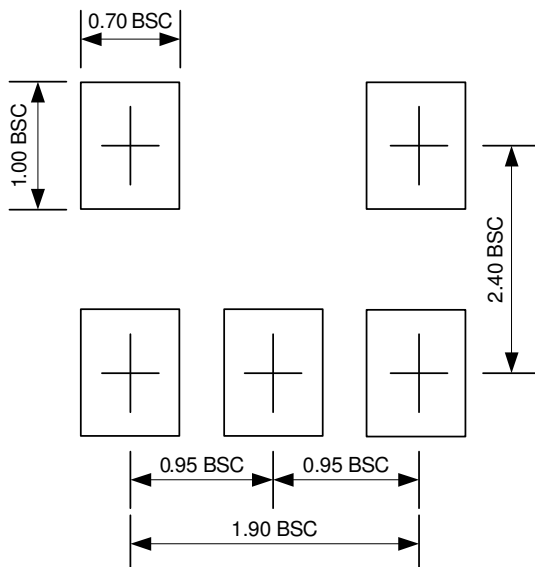
■ Lead Pattern Drawing

Note:

1. Lead pattern unit description:

BSC: Basic. Represents theoretical exact dimension or dimension target.

2. Dimensions in Millimeters.

3. General tolerance $\pm 0.05\text{mm}$ unless otherwise specified.



www.ame.com.tw
E-Mail: sales@ame.com.tw

Life Support Policy:

These products of AME, Inc. are not authorized for use as critical components in life-support devices or systems, without the express written approval of the president of AME, Inc.

AME, Inc. reserves the right to make changes in the circuitry and specifications of its devices and advises its customers to obtain the latest version of relevant information.

© AME, Inc. , November 2019

Document: A025A-DS8501-B.01

Corporate Headquarter
AME, Inc.

8F-1, 12, WenHu St., Nei-Hu

Taipei 114, Taiwan .

Tel: 886 2 2627-8687

Fax: 886 2 2659-2989