

■ General Description

The AME385-2.5 is a micropower 2-terminal band-gap voltage regulator diode. It operates over a 30µA to 20mA current range. Each circuit is trimmed at wafer sort to provide a ±0.50% and ±0.80% initial tolerance. The design of the AME385-2.5 allows for a large range of load capacitances and operating currents. The low start-up current makes these parts ideal for battery applications.

AME offers this part in a TO-92 and SOP-8 packages as well as the space saving SOT-23.

■ Features

- Small Packages: SOT-23, TO-92, SOP-8
- Tolerates Capacitive Loads
- Fixed Reverse Breakdown Voltage of 2.5V
- Tight Voltage Tolerance ----- ±0.50%, ±0.8%
- Wide Operating Current ----- 30µA to 20mA
- Wide Temperature Range ----- -40°C to +85°C
- Low Temperature Coefficient --100ppm/°C (max)
- Excellent Transient Response
- Green Products Meet RoHS Standards

■ Applications

- Portable Electronics
- Power Supplies
- Computer Peripherals
- Data Acquisition Systems
- Battery Chargers
- Consumer Electronics

■ Functional Block Diagram

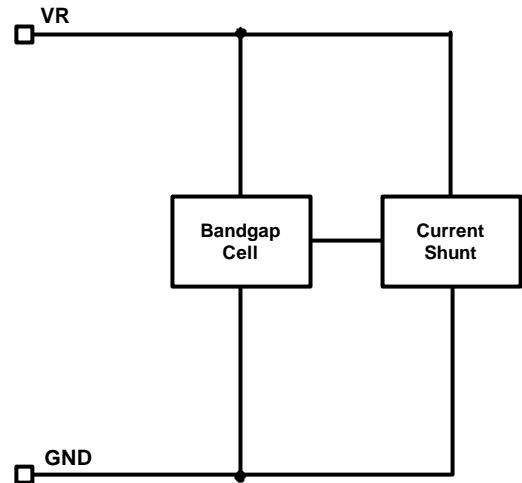

■ Typical Application

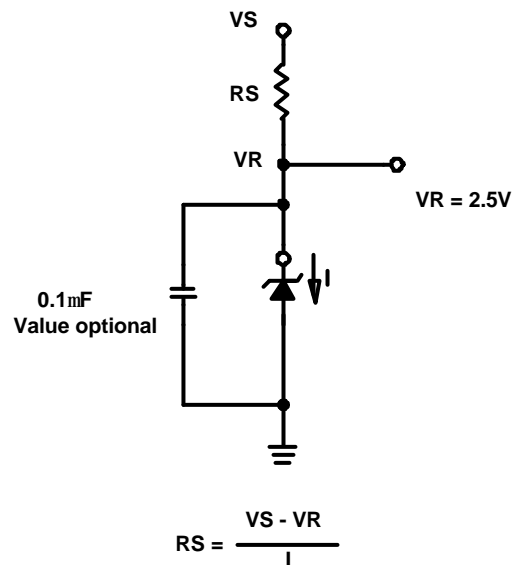

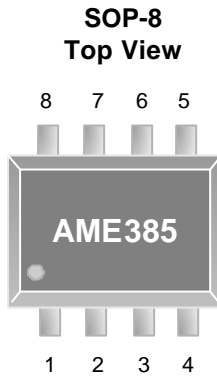
■ Pin Configuration

AME 385-2.5

1. NC
2. NC
3. NC
4. -
5. NC
6. NC
7. NC
8. +

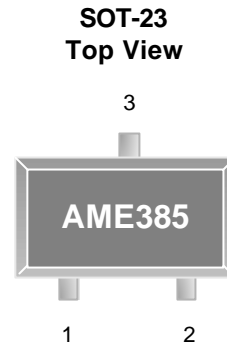
*** Die Attach:
Conductive Epoxy**

AME 385-2.5

1. +
2. -
3. NC*

*** Die Attach:
Non-Conductive Epoxy**

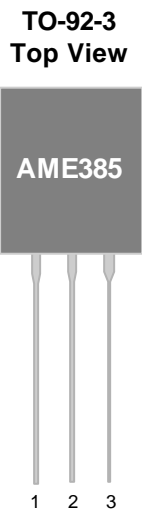
AME 385-2.5

1. NC*
2. +
3. -

*** Die Attach:
Non-Conductive Epoxy**

* The NC pin must float or be connected to - (negative)



AME385-2.5

Shunt Bandgap Voltage Reference

■ Ordering Information

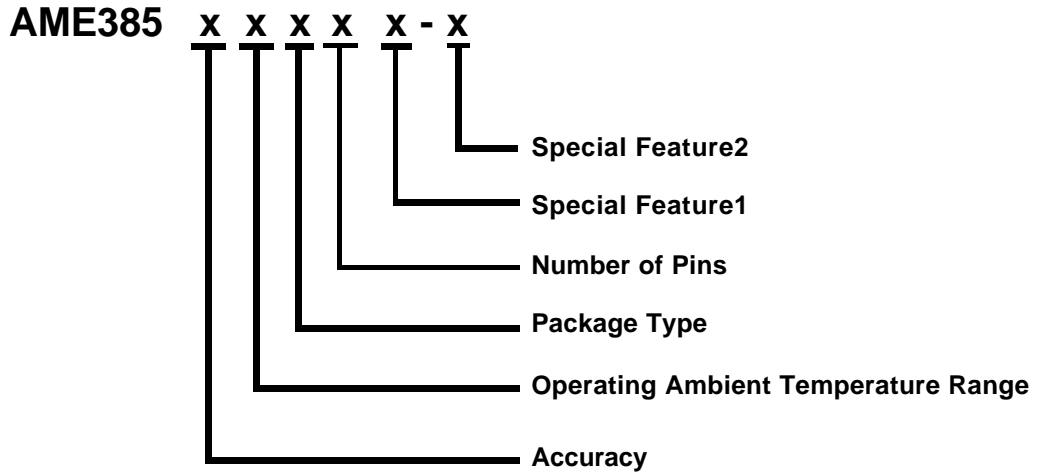

Accuracy	Operating Ambient Temperature Range	Package Type	Number of Pins	Special Feature1	Special Feature2 (For TO-92 Package Only)									
B: 0.5% <small>(SOT-23)</small> <small>(SOP-8)</small> F: 0.8% <small>(TO-92-3)</small>	E: -40°C to +85°C	A: TO-92 E: SOT-2X H: SOP	A: 8 T: 3	Z: Lead Free	<table border="1"> <thead> <tr> <th></th> <th>Package</th> <th>Lead Pitch</th> </tr> </thead> <tbody> <tr> <td>N/A:</td> <td>Taping</td> <td>5.08mm</td> </tr> <tr> <td>1:</td> <td>Bulk</td> <td>2.54mm</td> </tr> </tbody> </table>		Package	Lead Pitch	N/A:	Taping	5.08mm	1:	Bulk	2.54mm
	Package	Lead Pitch												
N/A:	Taping	5.08mm												
1:	Bulk	2.54mm												



AME385-2.5

Shunt Bandgap Voltage Reference

■ Ordering Information

Part Number	Marking	Accuracy	Package	Operating Ambient Temperature Range
AME385BEET	ABYww	0.5%	SOT-23	- 40°C to +85°C
AME385BEETZ	ABYww	0.5%	SOT-23	- 40°C to +85°C
AME385BEHAZ	385 BEHA yyww	0.5%	SOP-8	- 40°C to +85°C
AME385FEATZ	AME 385 FEAT yyww	0.8%	TO-92-3	- 40°C to +85°C
AME385FEATZ-1	AME 385 FEAT yyww	0.8%	TO-92-3	- 40°C to +85°C

Note:

1. yyww & ww represents the date code and pls refer to Date Code Rule page on Package Dimension.
2. A line on top of the first letter represents lead free plating such as \overline{A} BY.
3. Please consult AME sales office or authorized Rep./Distributor for the availability of voltage accuracy and package type.

■ Absolute Maximum Ratings

Parameter	Maximum	Unit
Supply Current	50	mA

Caution: Stress above the listed absolute maximum rating may cause permanent damage to the device

■ Recommended Operating Conditions

Parameter	Symbol	Rating	Unit
Ambient Temperature Range	T_A	- 40 to +85	°C
Junction Temperature Range	T_J	- 40 to +125	°C
Storage Temperature Range	T_{STG}	- 65 to +150	°C
Supply Current		100 μ A ~ 20mA	

■ Electrical Specifications

Unless otherwise specified, $T_A = 0$ to 70°C , $I = 100\mu\text{A}$

Parameter	Symbol	Test Condition	Min	Typ	Max	Units
Reference Voltage, $\pm 0.5\%$	V_{REF}	$I_{REF} = 100\mu\text{A}$	2.487	2.50	2.513	V
Reference Voltage, $\pm 0.8\%$			2.480	2.50	2.520	V
Minimum Current	I_{MIN}				30	μA
Reference Voltage Change With Current	$dV_{REF/I}$	$I_{MIN} \leq I \leq 1\text{mA}$		1.5	3	mV
		$1\text{mA} \leq I \leq 20\text{mA}$		5	20	
Maximum Operation Current	I_{Lmax}		20			mA
Reverse Dynamic Impedence	RDI	$I_R = 100\text{mA}$, $f = 20\text{Hz}$		1.5		Ohm
Wideband Noise (rms)	V_n	$I_R = 100\text{mA}$, $10\text{Hz} < f < 10\text{KHz}$		60		μV
Long term Stability		$I_R = 100\text{mA}$, $T_A = 25^\circ\text{C}$, $T = 1000$ Hours		20		ppm
Reference Voltage Temp. Coeff.	V_{REFTC}	$0^\circ\text{C} < T_A < 70^\circ\text{C}$			100	ppm/°C

■ Thermal Information

Parameter	Package	Die Attach	Symbol	Maximum	Unit
Thermal Resistance* (Junction to Case)	SOT-23	Non-Conductive Epoxy	θ_{JC}	140	°C / W
	TO-92-3			80	
	SOP-8	Conductive Epoxy		60	
Thermal Resistance (Junction to Ambient)	SOT-23	Non-Conductive Epoxy	θ_{JA}	280	°C / W
	TO-92-3			150	
	SOP-8	Conductive Epoxy		150	
Internal Power Dissipation	SOT-23	Non-Conductive Epoxy	P_D	400	mW
	TO-92-3			625	
	SOP-8	Conductive Epoxy		810	
Maximum Junction Temperature				150	°C
Solder Iron (10 Sec)**				350	°C

* Measure θ_{JC} on center of molding compound if IC has no tab.

** MIL-STD-202G 210F

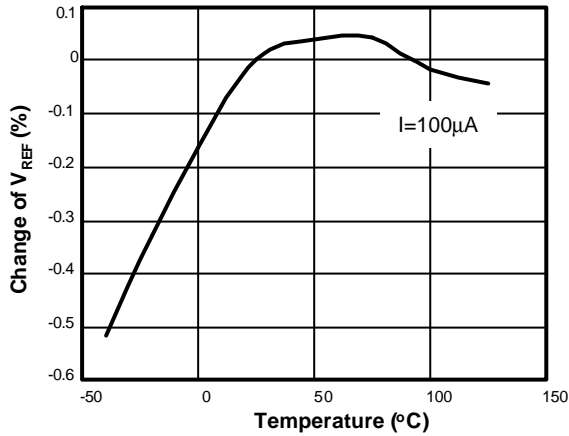
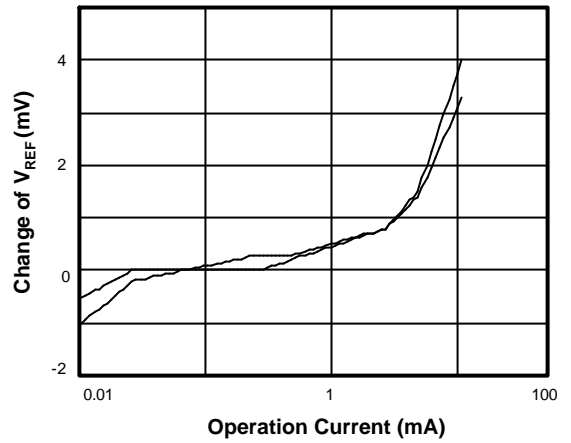
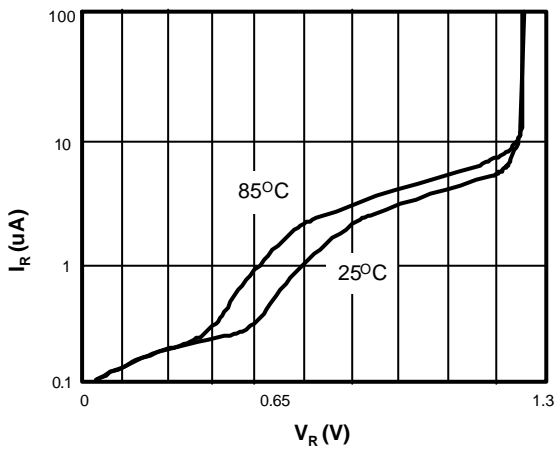
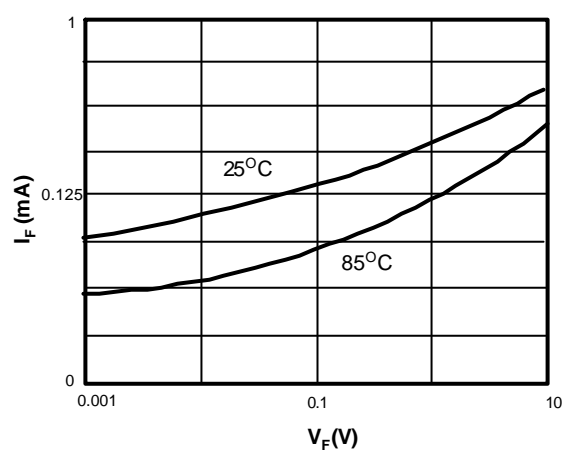
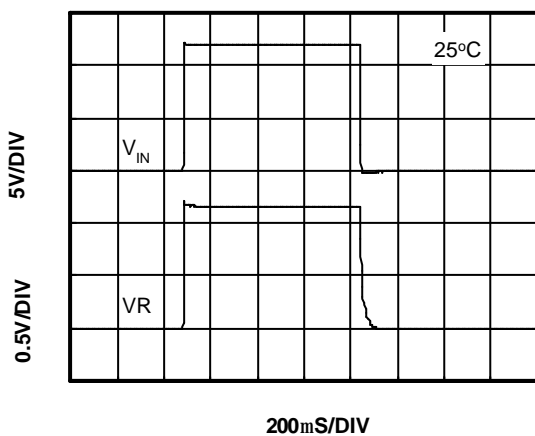
■ Characterization Curve(For reference only)
Normalized Percentage Change vs. Temp.

Reference Voltage Change vs. Current

Reverse Characteristic

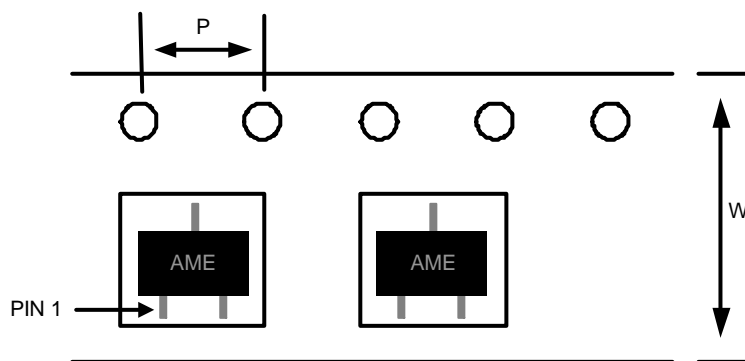
Forward Characteristic

Line Transient Response

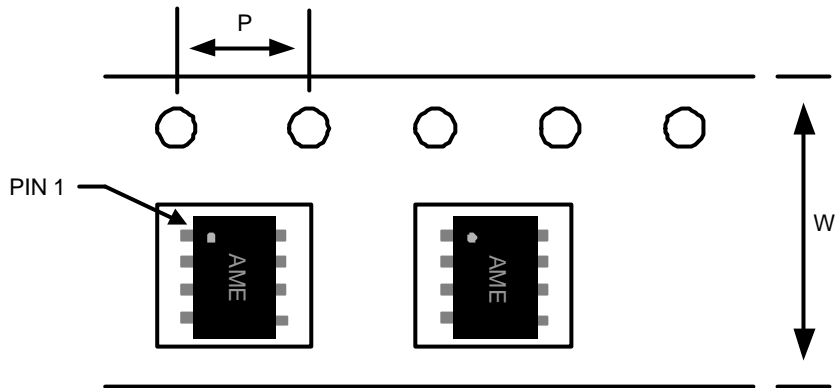
■ Date Code Rule

Marking			Date Code		Year
A	A	A	W	W	xxx0
A	A	A	W	<u>W</u>	xxx1
A	A	A	<u>W</u>	W	xxx2
A	A	A	<u>W</u>	<u>W</u>	xxx3
A	A	<u>A</u>	W	W	xxx4
A	A	<u>A</u>	W	<u>W</u>	xxx5
A	A	<u>A</u>	<u>W</u>	W	xxx6
A	A	<u>A</u>	<u>W</u>	<u>W</u>	xxx7
A	<u>A</u>	A	W	W	xxx8
A	<u>A</u>	A	W	<u>W</u>	xxx9

■ Tape and Reel Dimension (contd.)
SOT-23

Carrier Tape, Number of Components Per Reel and Reel Size

Package	Carrier Width (W)	Pitch (P)	Part Per Full Reel	Reel Size
SOT-23	8.0±0.1 mm	4.0±0.1 mm	3000pcs	180±1 mm

■ Tape and Reel Dimension
SOP-8

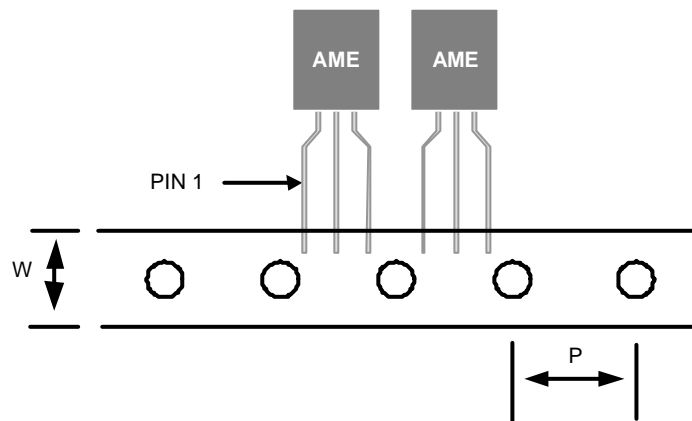
Carrier Tape, Number of Components Per Reel and Reel Size

Package	Carrier Width (W)	Pitch (P)	Part Per Full Reel	Reel Size
SOP-8	12.0±0.1 mm	4.0±0.1 mm	2500pcs	330±1 mm

TO-92-3

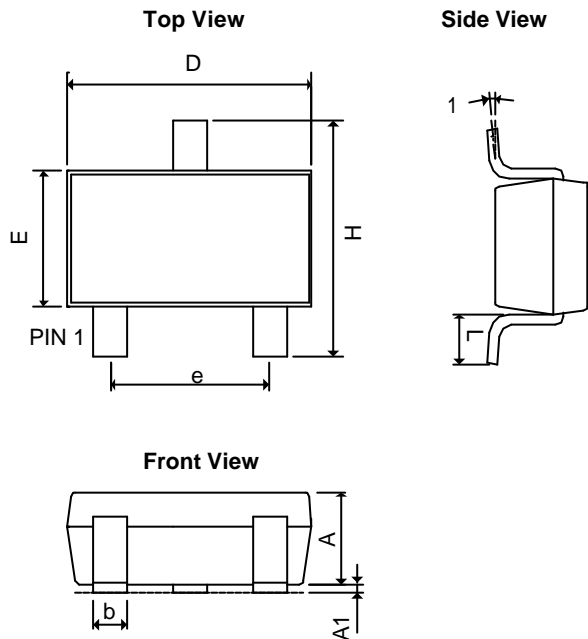
Carrier Tape, Number of Components Per Reel and Reel Size

Package	Carrier Width (W)	Pitch (P)	Part Per Full Reel	Reel Size
TO-92-3	18.0 ^{+1.0} _{-0.5} mm	12.7±0.2 mm	2000pcs	N/A

■ Package Dimension (contd.)
SOT-23

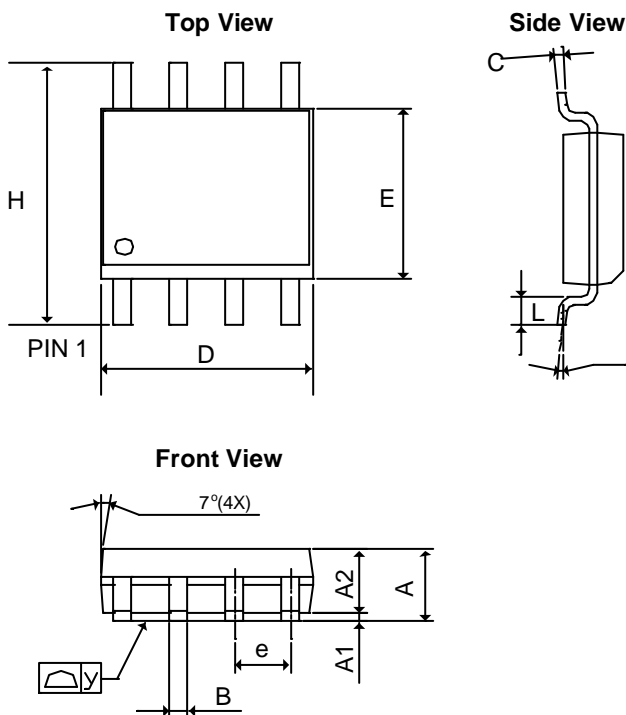
SYMBOLS	MILLIMETERS		INCHES	
	MIN	MAX	MIN	MAX
A	1.00	1.40	0.0394	0.0551
A ₁	0.00	0.15	0.0000	0.0059
b	0.35	0.50	0.0138	0.0197
D	2.70	3.10	0.1063	0.1220
E	1.40	1.80	0.0551	0.0709
e	1.90 BSC		0.0748 BSC	
H	2.40	3.00	0.09449	0.11811
L	0.35BSC		0.0138BSC	
q1	0°	10°	0°	10°

SOP-8

SYMBOLS	MILLIMETERS		INCHES	
	MIN	MAX	MIN	MAX
A	1.35	1.75	0.05315	0.0689
A ₁	0.10	0.30	0.00394	0.01181
A ₂	1.473 REF		0.05799 REF	
B	0.33	0.51	0.01299	0.02008
C	0.19	0.25	0.00748	0.00984
D	4.80	5.33	0.18898	0.20984
E	3.80	4.00	0.14961	0.15748
e	1.27 BSC		0.05000 BSC	
L	0.40	1.27	0.01575	0.05000
H	5.80	6.30	0.22835	0.24803
y	-	0.10	-	0.00394
q	0°	8°	0°	8°

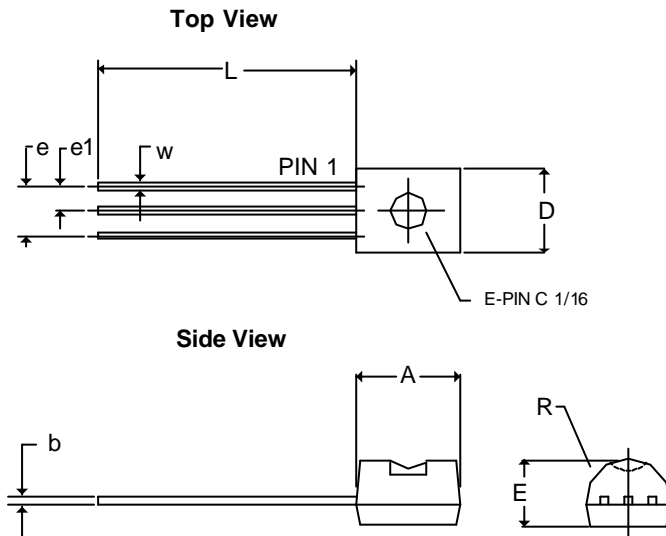
■ Package Dimension
TO-92-3 (bulk pack)

SYMBOLS	MILLIMETERS		INCHES	
	MIN	MAX	MIN	MAX
A	2.80	4.95	0.1102	0.1949
b	0.40REF		0.0157REF	
E	3.94REF		0.1551REF	
e	2.54REF		0.1000REF	
e1	1.27REF		0.0500REF	
L	12.70	15.49	0.5000	0.6098
R	2.29		0.0902	
W	0.35	0.76	0.0138	0.0299
D	3.80	4.95	0.1496	0.1949

- Notes:
1. Package outline exclusive of any mold flashes dimension.
 2. Package outline exclusive of burr dimension.
 3. Lead pitch=2.54mm is bulk pack.
 4. Lead pitch=5.08mm is tape pack.

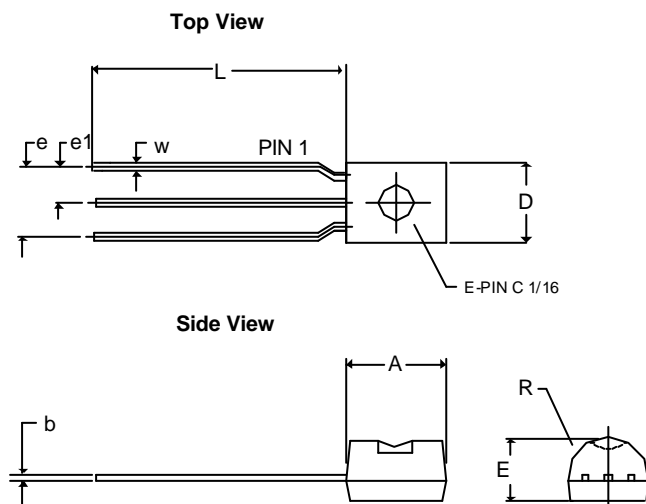
TO-92-3 (tape pack)

SYMBOLS	MILLIMETERS		INCHES	
	MIN	MAX	MIN	MAX
A	2.80	4.95	0.1102	0.1949
b	0.40REF		0.0157REF	
E	2.40	3.94	0.0945	0.1551
e	5.08REF		0.2REF	
e1	2.54REF		0.1REF	
L	12.70	15.49	0.5000	0.6098
R	2.00		0.0787	
W	0.35	0.76	0.0138	0.0299
D	3.80	4.95	0.1496	0.1949

- Notes:
1. Package outline exclusive of any mold flashes.
 2. Package outline exclusive of burr dimension.
 3. Lead pitch=2.54mm is bulk pack.
 4. Lead pitch=5.08mm is tape pack.



www.ame.com.tw
E-Mail: sales@ame.com.tw

Life Support Policy:

These products of AME, Inc. are not authorized for use as critical components in life-support devices or systems, without the express written approval of the president of AME, Inc.

AME, Inc. reserves the right to make changes in the circuitry and specifications of its devices and advises its customers to obtain the latest version of relevant information.

©AME, Inc. , February 2012

Document: 2003/2037-DS385-2.5-H.01

Corporate Headquarter
AME, Inc.

8F, 12, WenHu St., Nei Hu

Taipei, Taiwan. 114

Tel: 886 2 2627-8687

Fax: 886 2 2659-2989