

■ General Description

The AME5170 is a fixed off-time step-up DC/DC converter in a small SOT-25/TSOT-25A package. The AME5170 is ideal for LCD panels requiring low current and high efficiency as well as LED application for cellular phone backlighting, PDAs, and other hand-held devices. The low 400ns off time allows the use of tiny external components. AME5170 is designed to drive up to four white LEDs in series with a constant current from a single Li-Ion battery. To control LED brightness, the LED current can be adjusted by applying a PWM (pulse width modulated) signal with a frequency range of 100Hz to 50KHz to the EN pin.

■ Typical Application

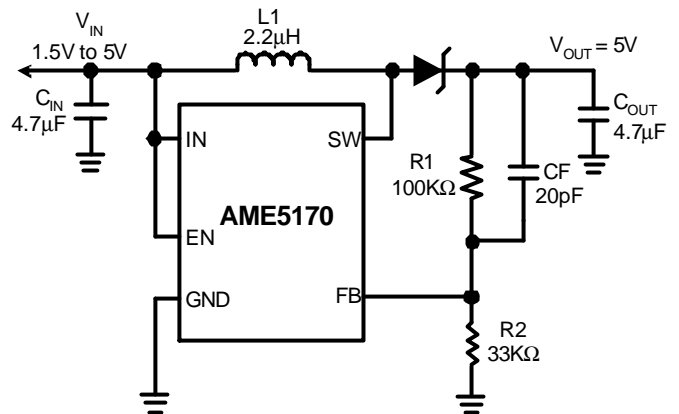

Figure.1 Typical 5V Application

■ Features

- 0.7Ω Internal Switch
- Use Small Surface Mount Components
- Adjust Output Voltage up to 28V
- Input under Voltage Lockout
- 0.1µA Shutdown Current Typical
- Small SOT-25/TSOT-25A Package
- All AME's Lead Free Products Meet RoHS Standards

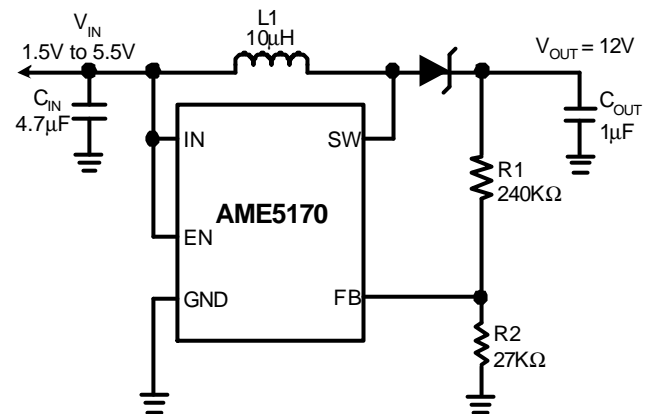

Figure.2 Typical 12V Application

■ Applications

- LCD Bias Supplies
- White LED Back-Lighting
- Handheld Devices
- Digital Cameras
- Portable Applications

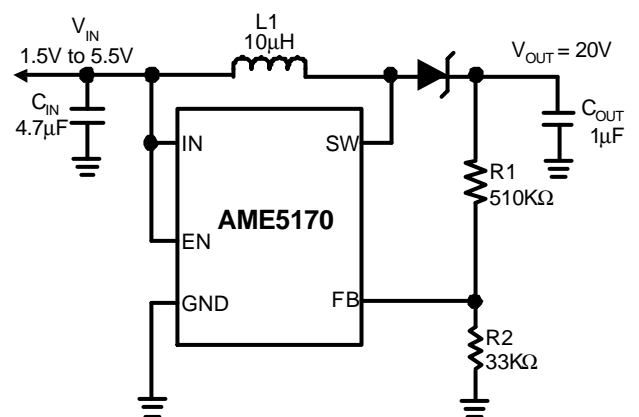

Figure.3 Typical 20V Application

AME5170

■ Typical Application

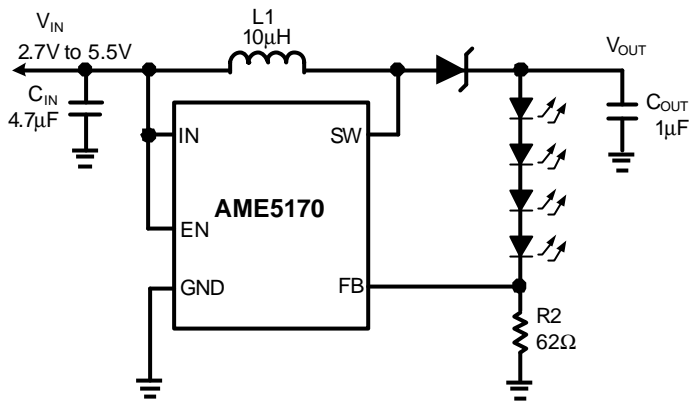

Figure.4 White LED Application

■ Function Block Diagram

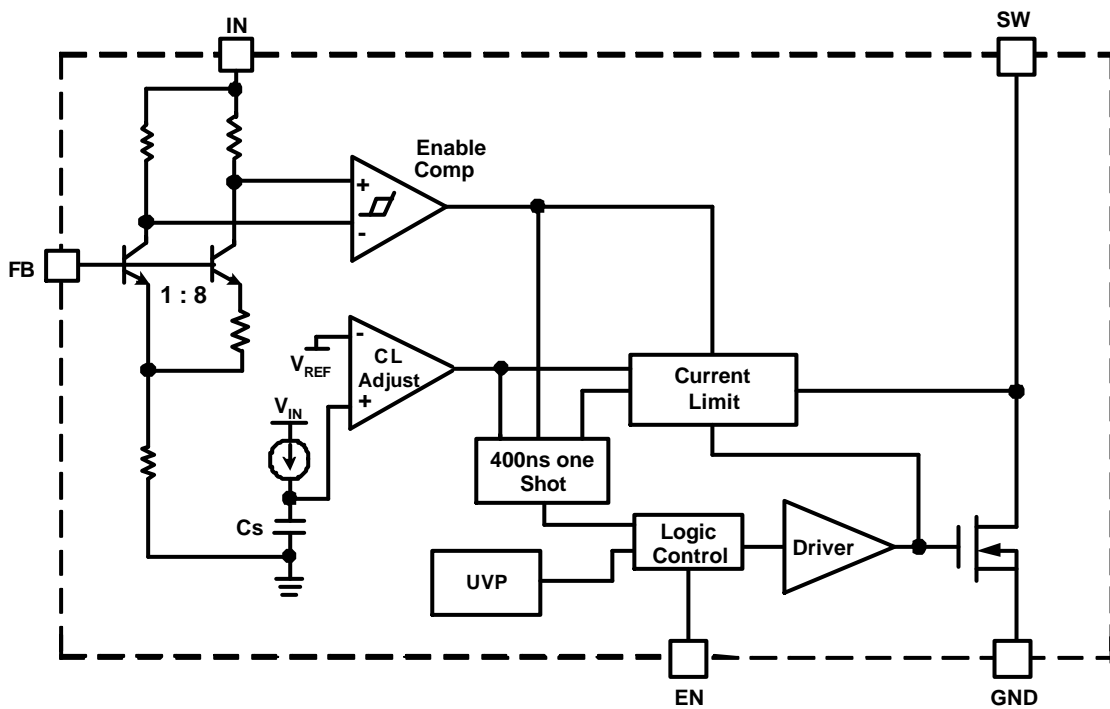
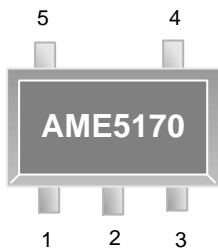

Figure.5 Function Block Diagram

■ Pin Configuration

SOT-25/TSOT-25A
Top View



AME5170AEEV

1. SW
2. GND
3. FB
4. EN
5. IN

Die Attach:

Conductive Epoxy

■ Pin Description

Pin Number	Pin Name	Pin Description
1	SW	Power Switch input. This is the drain of the internal NMOS power switch. Minimize the metal trace area connected to this pin to minimize EMI.
2	GND	Ground. Tie directly to ground plane.
3	FB	Output voltage feedback input. Set the output voltage by selecting values for R1 and R2 using: $R1 = R2 \left(\frac{V_{out}}{1.23V} - 1 \right)$ Connect the ground of the feedback network to an AGND(Analog Ground) plane which should be tied directly to the GND pin.
4	EN	Enable control input, active high. The enable pin is an active high control. Tie this pin above 1.5V to enable the device. Tie this pin below 0.4V to turn off the device.
5	IN	Analog and Power input. Input Supply Pin. Bypass this pin with a capacitor as close to the device as possible.

AME5170

■ Ordering Information

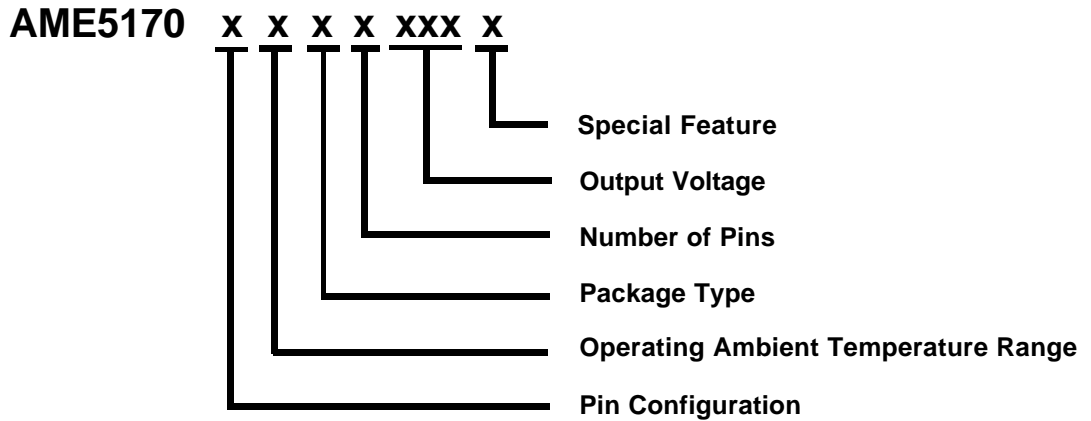

Pin Configuration	Operating Ambient Temperature Range	Package Type	Number of Pins	Output Voltage	Special Feature
A 1. SW (SOT-25) 2. GND (TSOT-25A) 3. FB 4. EN 5. IN	E: -40°C to +85°C	E: SOT-2X	V: 5	ADJ: Adjustable	Z: Lead free Y: Lead free & Low profile K: 0.9mm max height (for TSOT-2XA Only)

■ Ordering Information

Part Number	Marking*	Output Voltage	Package	Operating Ambient Temperature Range
AME5170AEEVADJZ	BLEww	ADJ	SOT-25	-40°C to +85°C
AME5170AEEVADJK	BLEww	ADJ	TSOT-25A	-40°C to +85°C

Note: ww represents the date code and pls refer to Date Code Rule on Package Dimension.

* A line on top of the first letter represents lead free plating such as BLEww.

Please consult AME sales office or authorized Rep./Distributor for the availability of package type.

■ Absolute Maximum Ratings

Parameter	Symbol	Maximum	Unit
Input Supply Voltage	V_{IN}	6	V
EN, FB Voltages	EN, V_{FB}	V_{IN}	V
SW Voltage	V_{SW}	$V_{OUT} + 0.3$	V
N-Channel Switch Sink Current	I_{SW}	600	mA
ESD Classification		B*	

Caution: Stress above the listed absolute rating may cause permanent damage to the device.

* HBM B: 2000~3999V

■ Recommended Operating Conditions

Parameter	Symbol	Rating	Unit
Ambient Temperature Range	T_A	- 40 to +85	°C
Junction Temperature Range	T_J	- 40 to +125	
Storage Temperature Range	T_{STG}	- 65 to +150	

■ Thermal Information

Parameter	Package	Die Attach	Symbol	Maximum	Unit
Thermal Resistance* (Junction to Case)	SOT-25	Conductive Epoxy	θ_{JC}	140	°C / W
	TSOT-25A			81	
Thermal Resistance (Junction to Ambient)	SOT-25		θ_{JA}	280	
	TSOT-25A			230	
Internal Power Dissipation	SOT-25		P_D	400	mW
	TSOT-25A			455	
Solder Iron (10Sec)**				350	°C

* Measure θ_{JC} on backside center of molding compound if IC has no tab.

** MIL-STD-202G 210F

AME5170

■ Electrical Specifications

$V_{IN} = 3.6V$, $EN = V_{IN}$, $T_A = 25^\circ C$, $C_{IN} = 4.7\mu F$, $I_L = 0A$, unless otherwise noted.

Parameter	Symbol	Test Condition	Min	Typ	Max	Units
Input Voltage	V_{IN}		1.5		5.5	V
Output Voltage Line Regulation				0.05		%V
Quiescent Current	I_Q	$V_{IN} = 2V$		65	75	μA
Shutdown Current	I_{SD}	$EN = 0V$		0.1	1	μA
FB Regulation Voltage	V_{FB}		1.20	1.23	1.26	V
FB Comparator Hysteresis	$V_{FB \text{ Hysteresis}}$			5		mV
Switch Current Limit	I_{CL}		300	375	450	mA
FB Pin Bias Current	I_{FB}	$V_{FB} = 1.23V$			1.0	μA
Switch R_{DSON}	R_{DSON}		0.6	1.0	1.4	Ω
Switch Off Time	t_{OFF}			400		nS
Input Undervoltage Lockout	UVLO			1.2	1.4	V
EN Input Threshold (High) (Enable the device)	EN Threshold		1.5			V
EN Input Threshold (Low) (Shutdown)					0.4	

■ Detailed Description

The AME5170 features a constant off-time control scheme. Operation can be best understood by referring to Figure 5. When the voltage at the FB pin is less than 1.23V, the Enable Comp in Figure.5 enables the device and the NMOS switch is turned on, pulling the SW pin to ground. When the NMOS switch is on, load current is supplied by the output capacitor C_{OUT} . Once the current in the inductor reaches the peak current limit, the 400ns One Shot turns off the NMOS switch. The SW voltage will then rise to the output voltage plus a diode drop and inductor current will begin to decrease as shown in Figure3. During this time the energy stored in the inductor is transferred to C_{OUT} and the load. After the 400ns off-time the NMOS switch is turned on and energy is stored in the inductor again. This energy transfer from the inductor to the output causes a stepping effect in the output ripple.

This cycle is continued until the voltage at FB pin reaches 1.23V. When FB pin reaches this voltage, the enable comparator then disables the device turning off the NMOS switch and reducing the quiescent current of the device to 65 μ A typical. The load current is then supplied solely by C_{OUT} indicated by the gradually decreasing slope at the output. When the FB pin drops slightly below 1.23V, the enable comparator enables the device and begins the cycle described previously. The EN pin can be used to turn off the AME5170 and reduce the I_Q to 0.1 μ A. In shutdown mode the output voltage will be a diode drop lower than the input voltage.

DIODE SELECTION

To maintain high efficiency, the average current rating of the schottky diode should be larger than the peak inductor current. Schottky diodes with a low forward drop and fast switching speeds are ideal for increasing efficiency in portable applications. Choose a reverse breakdown of the schottky diode larger than the output voltage

CAPACITOR SELECTION

Choose low ESR capacitors for the output to minimize output voltage ripple. Multilayer ceramic capacitors are the best choice. For most applications, a 1 μ F ceramic capacitor is sufficient. For some applications a reduction in output voltage ripple can be achieved by increasing the output capacitor. Local bypassing for the input is needed on the AME5170. Multilayer ceramic capacitors are a good choice for this as well. A 4.7 μ F capacitor is sufficient for most applications. For additional bypassing, a 100nF ceramic capacitor can be used to shunt high frequency ripple on the input.

LAYOUT CONSIDERATIONS

The input bypass capacitor C_{IN} , as shown in Figure 3, must be placed close to the IC. This will reduce copper trace resistance which effects input voltage ripple of the IC. For additional input voltage filtering, a 100nF bypass capacitor can be placed in parallel with C_{IN} to shunt any high frequency noise to ground. The output capacitor, C_{OUT} , should also be placed close to the IC. Any copper trace connections for the C_{OUT} capacitor can increase the series resistance, which directly effects output voltage ripple. The feedback network, resistors R1 and R2, should be kept close to the FB pin to minimize copper trace connections that can inject noise into the system. The ground connection for the feedback resistor network should connect directly to an analog ground plane. The analog ground plane should tie directly to the GND pin. If no analog ground plane is available, the ground connection for the feedback network should tie directly to the GND pin. Trace connections made to the inductor and schottky diode should be minimized to reduce power dissipation and increase overall efficiency.

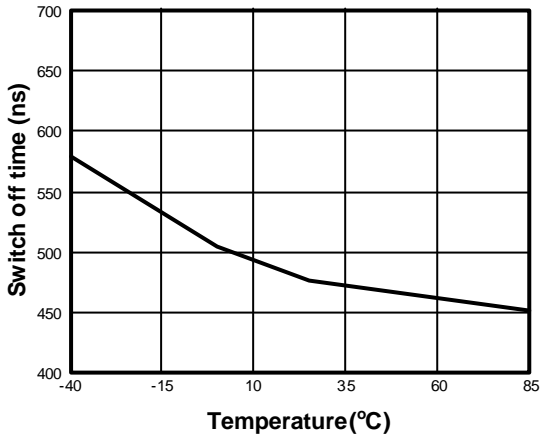
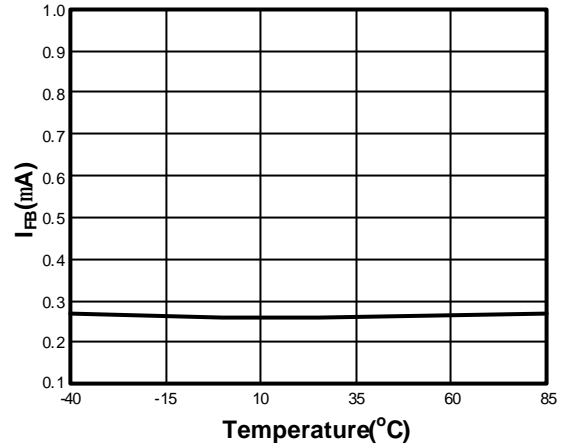
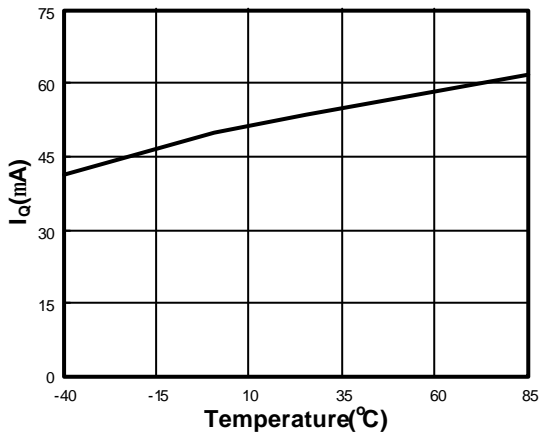
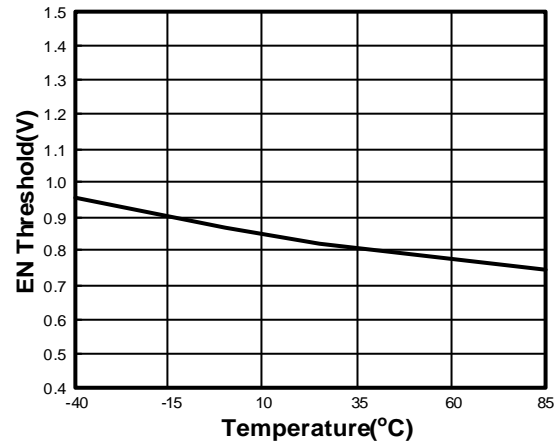
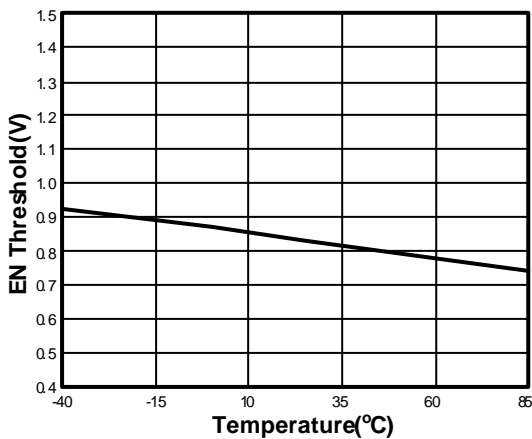
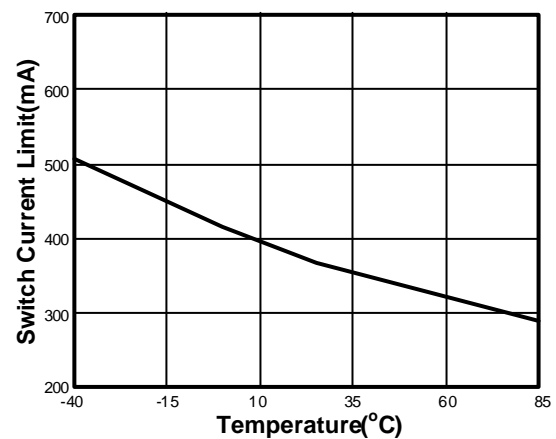
■ Characterization Curve
Switch off Time vs Temperature

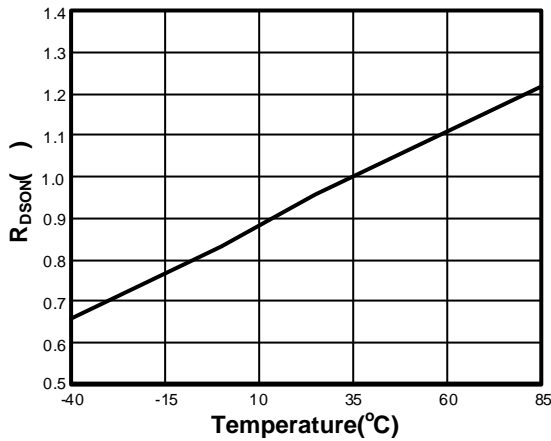
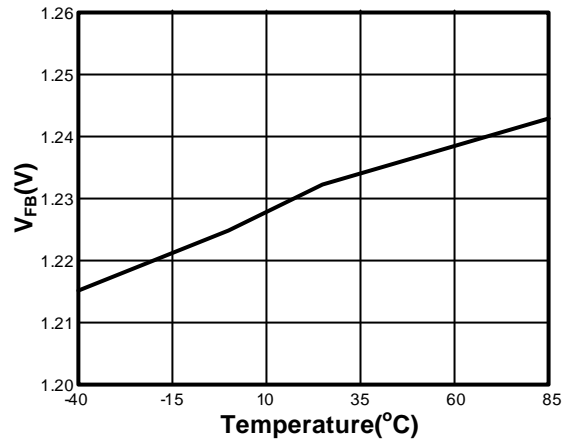
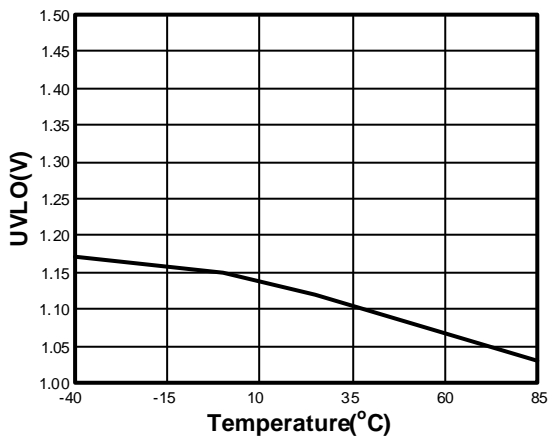
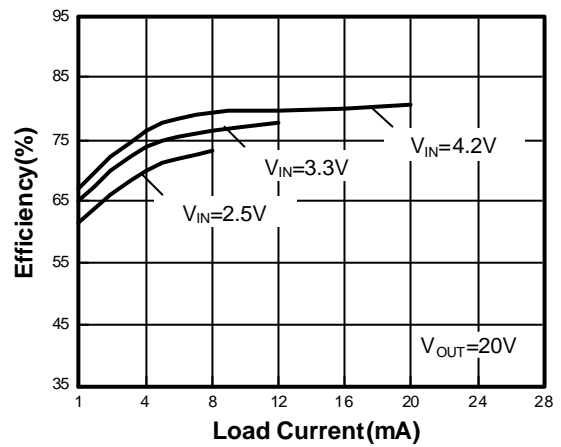
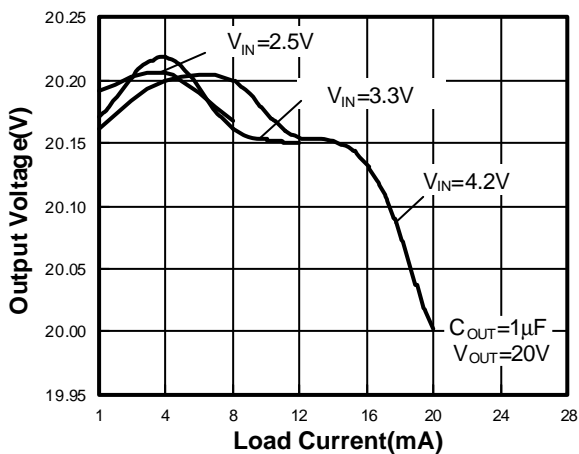
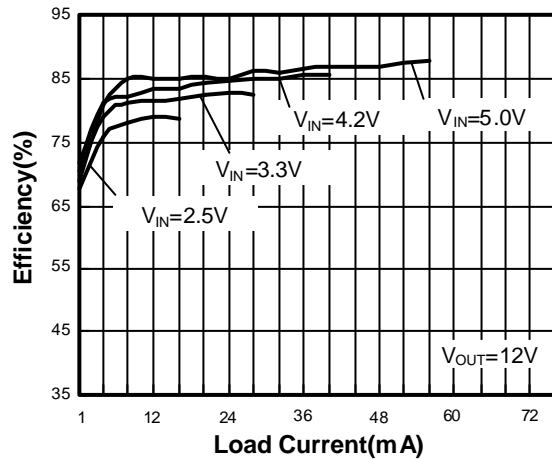
 I_{FB} vs Temperature

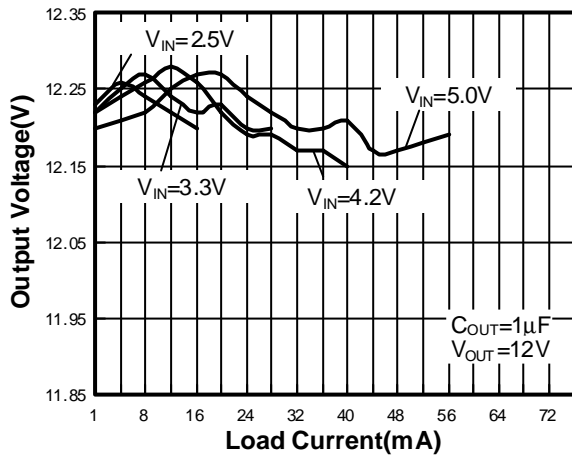
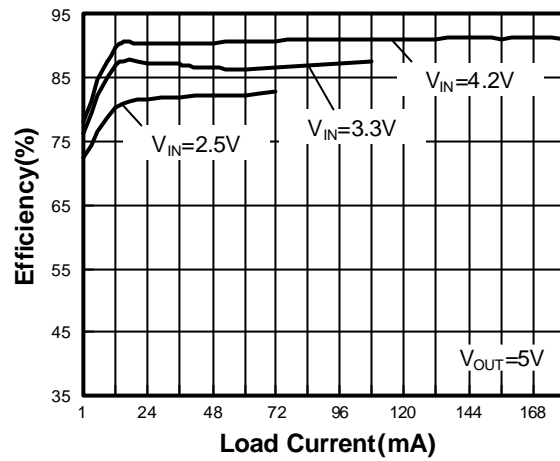
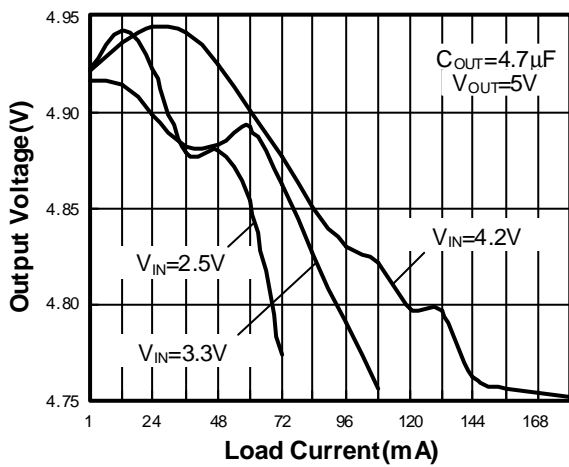
 I_Q vs Temperature

EN Thershold High vs Temperature

EN Threshold Low vs Temperature

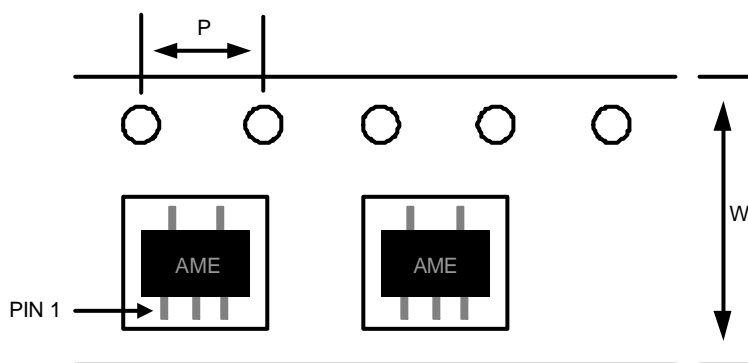
Switch Current Limit vs Temperature

■ Characterization Curve
 $R_{DS(on)}$ vs Temperature

 V_{FB} vs Temperature

UVLO vs Temperature

Efficiency vs Load Current

Output Voltage vs Load Current

Efficiency vs Load Current

■ Characterization Curve
Output Voltage vs Load Current

Efficiency vs Load Current

Output Voltage vs Load Current

■ Date Code Rule

Marking			Date Code		Year
A	A	A	W	W	xxx0
A	A	A	W	<u>W</u>	xxx1
A	A	A	<u>W</u>	W	xxx2
A	A	A	<u>W</u>	<u>W</u>	xxx3
A	A	<u>A</u>	W	W	xxx4
A	A	<u>A</u>	W	<u>W</u>	xxx5
A	A	<u>A</u>	<u>W</u>	W	xxx6
A	A	<u>A</u>	<u>W</u>	<u>W</u>	xxx7
A	<u>A</u>	A	W	W	xxx8
A	<u>A</u>	A	W	<u>W</u>	xxx9

■ Tape and Reel Dimension
SOT-25

Carrier Tape, Number of Components Per Reel and Reel Size

Package	Carrier Width (W)	Pitch (P)	Part Per Full Reel	Reel Size
SOT-25	8.0±0.1 mm	4.0±0.1 mm	3000pcs	180±1 mm

AME5170

■ Tape and Reel Dimension

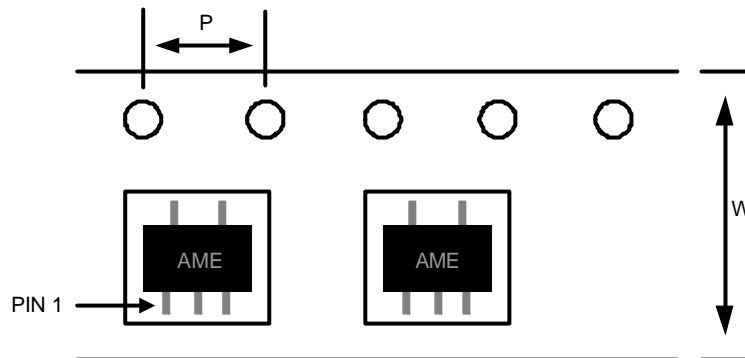
TSOT-25A



Carrier Tape, Number of Components Per Reel and Reel Size

Package	Carrier Width (W)	Pitch (P)	Part Per Full Reel	Reel Size
TSOT-25A	8.0±0.1 mm	4.0±0.1 mm	3000pcs	180±1 mm

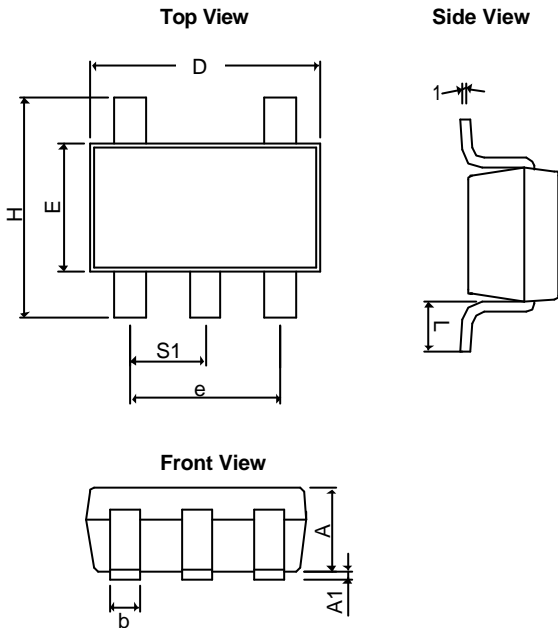
■ Package Dimension
SOT-25

SYMBOLS	MILLIMETERS		INCHES	
	MIN	MAX	MIN	MAX
A	1.20REF		0.0472REF	
A ₁	0.00	0.15	0.0000	0.0059
b	0.30	0.55	0.0118	0.0217
D	2.70	3.10	0.1063	0.1220
E	1.40	1.80	0.0551	0.0709
e	1.90 BSC		0.07480 BSC	
H	2.60	3.00	0.10236	0.11811
L	0.37BSC		0.0146BSC	
q1	0°	10°	0°	10°
S ₁	0.95BSC		0.0374BSC	

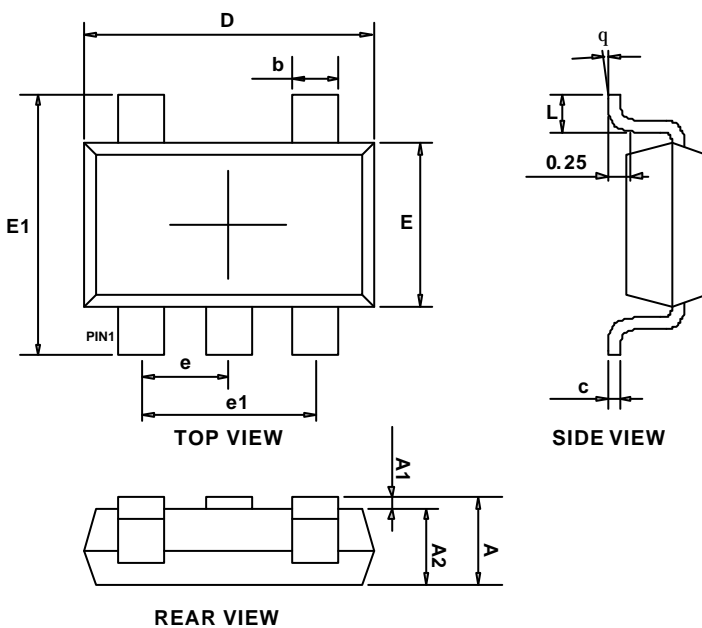
TSOT-25A

SYMBOLS	MILLIMETERS		INCHES	
	MIN	MAX	MIN	MAX
A	0.700	0.900	0.028	0.035
A ₁	0.000	0.100	0.000	0.004
A ₂	0.700	0.800	0.028	0.031
b	0.350	0.500	0.014	0.020
c	0.080	0.200	0.003	0.008
D	2.820	3.020	0.111	0.119
E	1.600	1.700	0.063	0.067
E ₁	2.650	2.950	0.104	0.116
e	0.95 BSC		0.037 BSC	
e ₁	1.90 BSC		0.075 BSC	
L	0.300	0.600	0.012	0.024
q	0°	8°	0°	8°

AME5170

■ Lead pattern

SOT-25

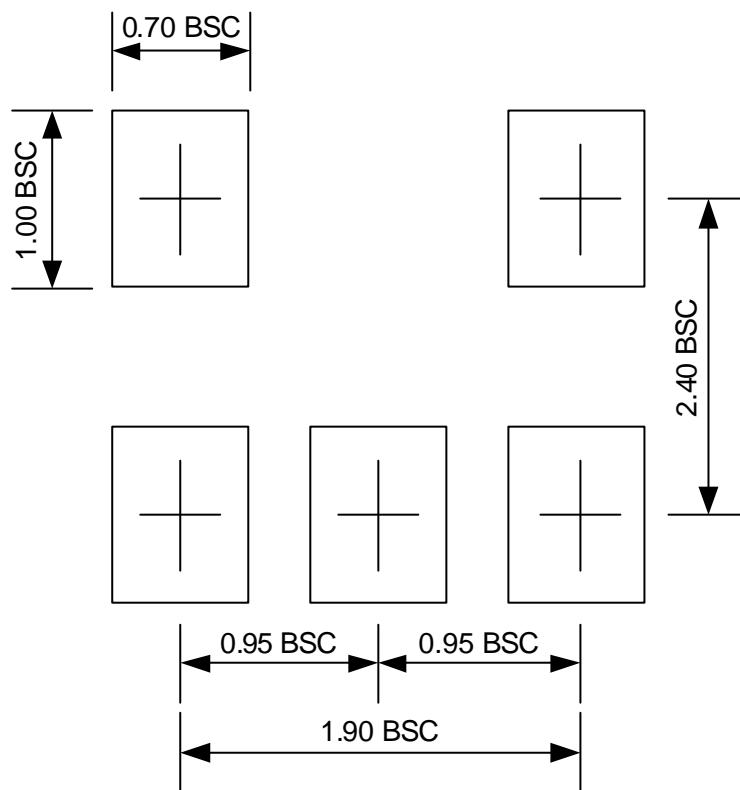

Note:

1. Lead pattern unit description:

BSC: Basic. Represents theoretical exact dimension or dimension target.

2. Dimensions in Millimeters.

3. General tolerance $\pm 0.05\text{mm}$ unless otherwise specified.

■ Lead pattern

TSOT-25A

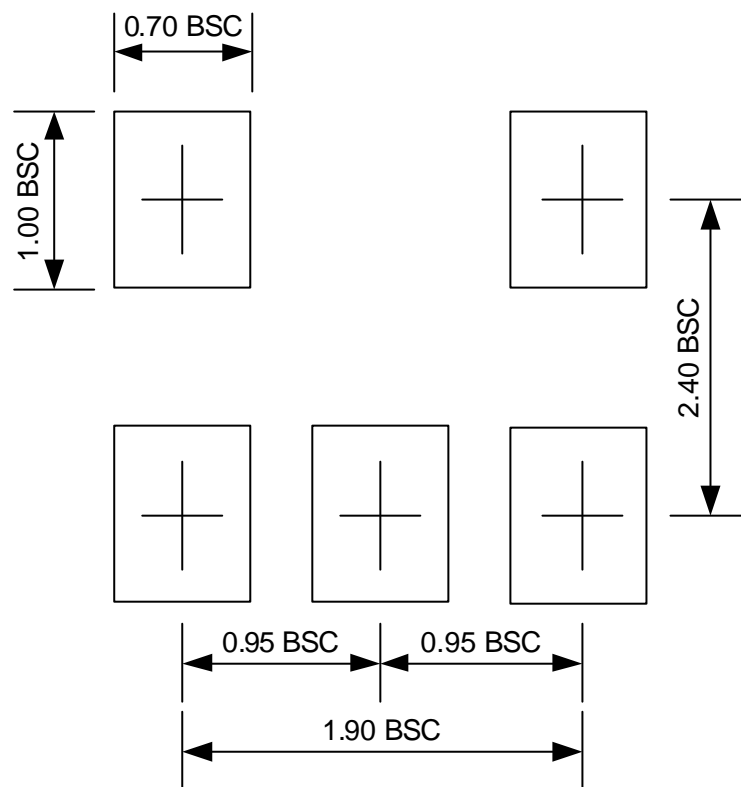

Note:

1. Lead pattern unit description:

BSC: Basic. Represents theoretical exact dimension or dimension target.

2. Dimensions in Millimeters.

3. General tolerance $\pm 0.05\text{mm}$ unless otherwise specified.



www.ame.com.tw
E-Mail: sales@ame.com.tw

Life Support Policy:

These products of AME, Inc. are not authorized for use as critical components in life-support devices or systems, without the express written approval of the president of AME, Inc.

AME, Inc. reserves the right to make changes in the circuitry and specifications of its devices and advises its customers to obtain the latest version of relevant information.

© AME, Inc. , October 2011

Document: 1231-DS5170-A.05

Corporate Headquarter
AME, Inc.

2F, 302 Rui-Guang Road, Nei-Hu District

Taipei 114, Taiwan, R.O.C.

Tel: 886 2 2627-8687

Fax: 886 2 2659-2989