

■ General Description

The AME5290 is a synchronous buck converter with internal power MOSFETs. It achieves 3A continuous output current with a fixed frequency of 1MHz with excellent load and line regulation. The device operates from an input voltage of 3V to 5.5V and provides an output voltage from 0.8V to V_{IN} , making the AME5290 ideal for on-board post regulation applications.

Internal soft-start minimizes the inrush supply current at startup. The circuit protection includes cycle-by-cycle current limiting, output short circuit frequency protection and thermal shutdown these protect functions improve design reliability.

This device is available in SOP-8/PP package with exposed pad for low thermal resistance.

■ Features

- Input Voltage Operate from 3V to 5.5V
- 3A Output Current
- 100m Ω Internal Power MOSFET Switch
- Stable with Low ESR Output Ceramic Capacitors
- Up to 95% Efficiency
- Thermal Shutdown
- Output Adjustable from 0.8V to V_{IN}
- Short Circuit Frequency Protection
- Over Temperature Protection
- Available in SOP-8/PP Package
- Green Products Meet RoHS Standards

■ Applications

- TV
- Distributed Power Systems
- Pre-Regulator for Linear Regulators

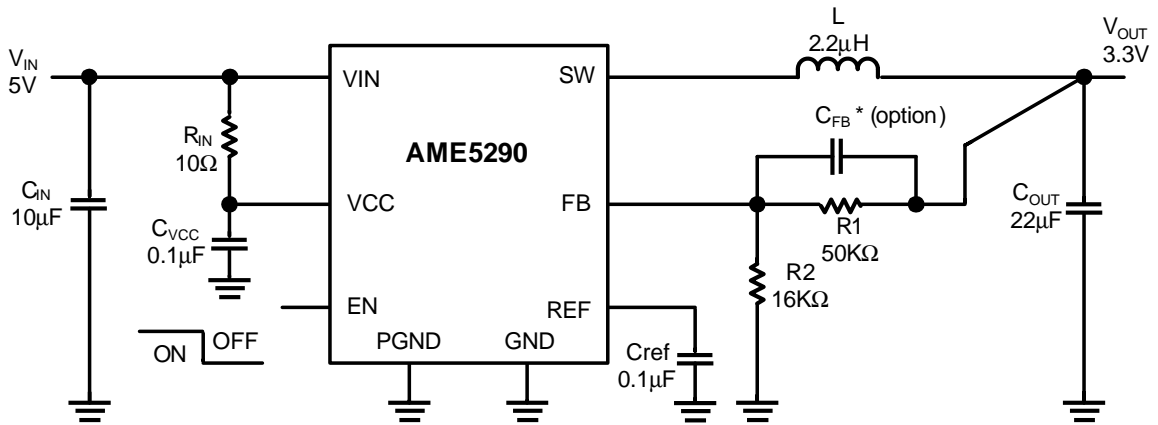
Typical Operating Circuit

$$V_{OUT} = 0.8V \times \left(1 + \frac{R1}{R2}\right)$$

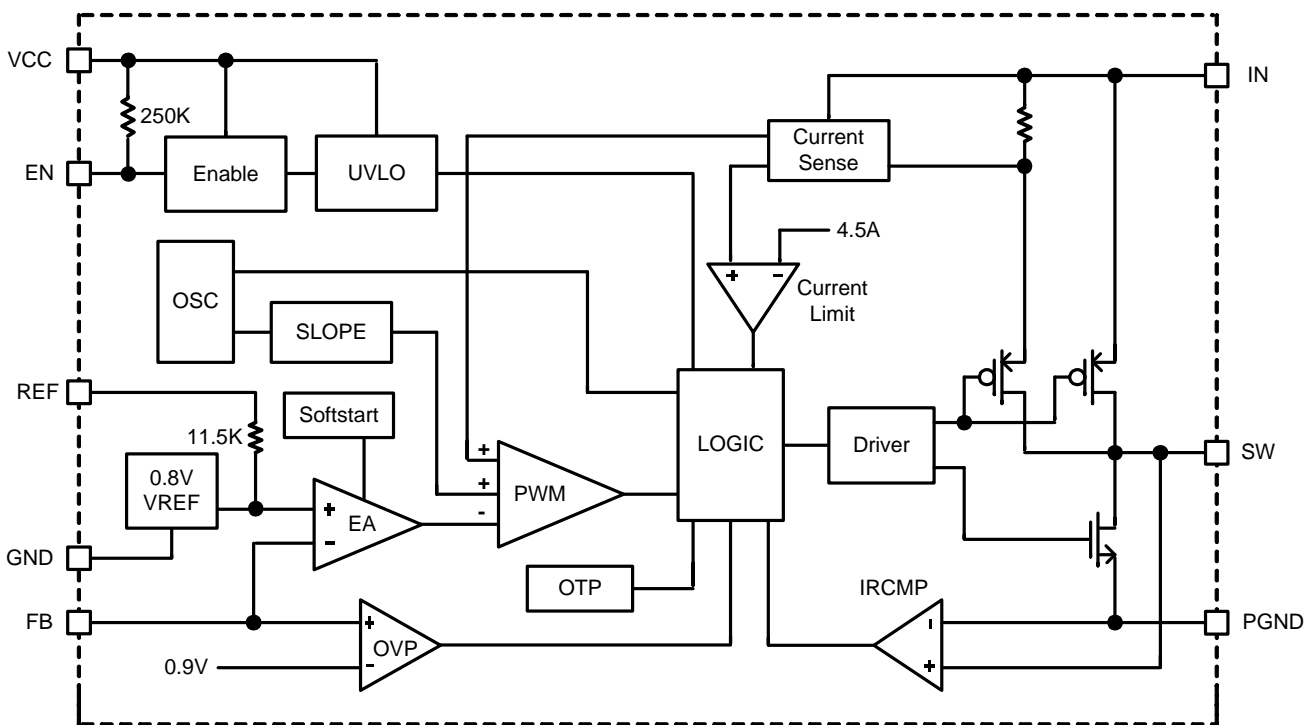
Functional Block Diagram

■ Pin Configuration

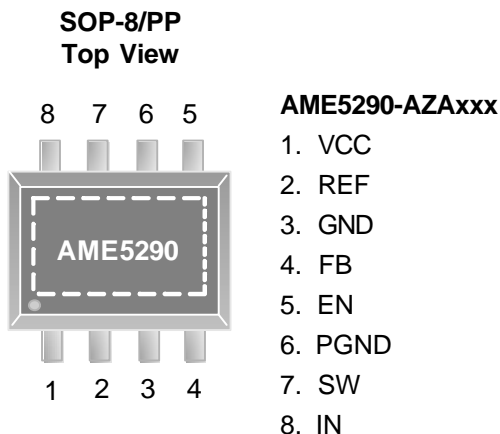

*** Die Attach:
Conductive Epoxy**

Note:
Connect exposed pad (heat sink on the back) to GND.

■ Pin Description

Pin Number	Pin Name	Pin Description
1	VCC	Supply Voltage. Bypass with 0.1 μ F capacitor to ground and 10 Ω resistor to V_{IN} .
2	REF	Reference Bypass. Bypass with 0.1 μ F capacitor to ground.
3	GND	Ground. Connect the exposed pad to GND.
4	FB	Feedback Input. FB senses the output voltage to regulate that voltage. Drive FB with a resistive voltage divider from the output voltage. The feedback reference voltage is 0.8V.
5	EN	Enable. Internal pull high with a resistor. Pull EN below 0.4V to shut down the regulator.
6	PGND	Power Ground. Internally connected to GND. Keep power ground and signal ground planes separate.
7	SW	Power Switching Output. SW is the switching node that supplies power to the output. Connect the output LC filter from SW to the output load.
8	IN	Power-Supply Voltage. Input voltage range from 3V to 5.5V. Bypass with a 10 μ F (min.) ceramic capacitor to ground and a 10 Ω resistor to VCC.

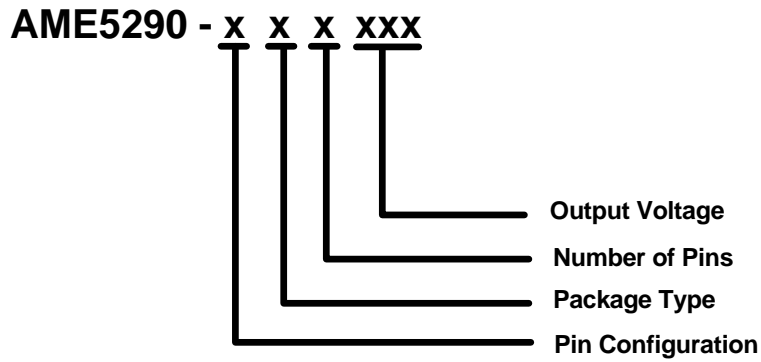
■ Ordering Information

Pin Configuration	Package Type	Number of Pins	Output Voltage
A (SOP-8/PP) 1. VCC 2. REF 3. GND 4. FB 5. EN 6. PGND 7. SW 8. IN	Z: SOP/PP	A: 8	ADJ: Adjustable

■ Available Options

Part Number	Marking*	Output Voltage	Package	Operating Ambient Temperature Range
AME5290-AZAADJ	A5290 AMyMXX	ADJ	SOP-8/PP	-40°C to +85°C

Note:

1. The first 2 places represent product code. It is assigned by AME such as AM.
2. y is year code and is the last number of a year. Such as the year code of 2008 is 8.
3. A bar on top of first letter represents Green Part such as \bar{A} 5290.
4. The last 3 places MXX represent Marking Code. It contains M as date code in "month", XX as LN code and that is for AME internal use only. Please refer to date code rule section for detail information.
5. Please consult AME sales office or authorized Rep./Distributor for the availability of output voltage and package type.

■ Absolute Maximum Ratings

Parameter	Maximum	Unit
VIN, VCC, REF to GND	-0.3V to +6V	V
Switch Voltage	-1V to +6V	V
EN, FB to GND	-0.3V to (VCC + 0.3V)	V
PGND to GND	-0.3V to +0.3V	V
ESD Classification	B*	

Caution: Stress above the listed in absolute maximum ratings may cause permanent damage to the device.

* HBM B: 2000V ~ 3999V

■ Recommended Operating Conditions

Parameter	Symbol	Rating	Unit
Ambient Temperature Range	T_A	-40 to +85	°C
Junction Temperature Range	T_J	-40 to +125	
Storage Temperature Range	T_{STG}	-65 to +150	

■ Thermal Information

Parameter	Package	Die Attach	Symbol	Maximum	Unit
Thermal Resistance* (Junction to Case)	SOP-8/PP	Conductive Epoxy	θ_{JC}	19	°C / W
Thermal Resistance (Junction to Ambient)			θ_{JA}	84	
Internal Power Dissipation			P_D	1450	mW
Maximum Junction Temperature				150	°C
Solder Iron (10Sec)**				350	

* Measure θ_{JC} on center of molding compound if IC has no tab.

** MIL-STD-202G 210F

■ Electrical Specifications
 $V_{IN}=5V, T_A = 25^{\circ}C$ unless otherwise noted.

Parameter	Symbol	Test Condition	Min	Typ	Max	Units
Input Voltage Range	V_{IN}		3		5.5	V
Supply Current		No switching (EN=VCC)		450		μA
Shutdown Current	I_{SHDN}	Shutdown (EN=0V)				
V_{CC} Undervoltage Lockout Threshold		When SW starts switching		2		V
REF Voltage	V_{REF}	$I_{REF}=0, V_{IN}=3V$ to 5V		0.8		V
EN Voltage High	V_{EN}	Logic High	2			V
EN Voltage Low		Logic Low			0.4	
Output Voltage Range	V_{OUT}	When using external feedback resistors to drive FB	0.8		V_{IN}	V
Output Voltage Line Regulation		$V_{IN}=3V$ to 5V		0.08		%/V
Output Voltage Load Regulation		$0A < I_{LOAD} < 3A$		0.12		%/A
Feedback Voltage (Error Amp Only)	V_{FB}	$V_{IN}=3V$ to 5V	0.784	0.8	0.816	V
FB Input Bias Current			-0.1		0.1	μA
High-side Switch On Resistance	$R_{DSON,HI}$	$V_{IN}=5V$		100		m Ω
Low-side Switch On Resistance	$R_{DSON,LOW}$	$V_{IN}=5V$		80		
High-side Switch Current Limit		Duty cycle=100%, $V_{IN}=3V$ to 5V	High-side	3.4	4.5	A
Low-side Switch Current Limit			Low-side		-1.3	
Switch Leakage Current	I_{SWLK}	$V_{IN}=5V$	$V_{SW}=5V$		10	μA
			SW=GND	-10		
Current Limit Oscillation Frequency	$f_{OSC,CL}$	$V_{IN}=3V$ to 5V		1		MHz
Short Current Oscillation Frequency	$f_{OSC,SCR}$	$V_{FB}=0V$		120		KHz
SW Maximum Duty Cycle	$D_{SW,MAX}$	$V_{SW}=high-Z, V_{IN}=3V$ to 5V			100	%
SW Minimum Duty Cycle	$t_{SWON,MIN}$	$V_{IN}=3V$ to 5V		15		



AME5290

3A, 1MHz Sync Buck Converter

■ Electrical Specifications (Contd.)

Parameter	Symbol	Test Condition		Min	Typ	Max	Units
Thermal Shutdown Temperature	OTP	When SW starts/stops switching	TJ rising		160		°C
Thermal Shutdown Hysteresis	OTH				20		
Minimum On Time	$t_{ON,MIN}$				150		ns

■ Detailed Description

The AME5290 high-efficiency switching regulator is a small, simple, DC-to-DC step-down converters capable of delivering up to 3A of output current. The devices operate in pulse-width modulation (PWM) at a fixed frequency of 1MHz from a 3V to 5.5V input voltage and provide an output voltage from 0.8V to V_{IN} , making the AME5290 ideal for on-board post-regulation applications. The high switching frequency allows for the use of smaller external components, and internal synchronous rectifiers improve efficiency and do not use the typical Schottky free-wheeling diode. Using the on-resistance of the internal high-side MOSFET to sense switching currents eliminates current-sense resistors, further improving efficiency and cost.

The AME5290 step-down converters use a PWM current-mode control scheme. An open-loop comparator (Modulator) compares the amplified voltage-feedback signal against the sum of the amplified current-sense signal and the slope compensation ramp. At each rising edge of the internal clock, the internal high-side MOSFET turns on until the PWM comparator trips. During this on-time, current ramps up through the inductor, sourcing current to the output and storing energy in the inductor. The current-mode feedback system regulates the peak inductor current as a function of the output voltage error signal. Since the average inductor current is nearly the same as the peak inductor current (<30% ripple current). The circuit acts as a switch-mode transconductance amplifier. To preserve inner-loop stability and eliminate inductor stair-casing, a slope-compensation ramp is summed into the main PWM comparator. During the second half of the cycle, the internal high-side P-channel MOSFET turns off, and the internal low-side N-channel MOSFET turns on. The inductor releases the stored energy as its current ramps down while still providing current to the output. The output capacitor stores charge when the inductor current exceeds the load current, and discharges when the inductor current is lower, smoothing the voltage across the load.

Current Limit

The internal high-side MOSFET has a current limit of 4.5A (typ.). If the current flowing out of SW exceeds this limit, the high-side MOSFET turns off and the synchronous rectifier turns on. This lowers the duty cycle and causes the output voltage to droop until the current limit is no longer exceeded. A synchronous rectifier current limit of -1.3A (typ.) protects the device from current flowing into SW. If the negative current limit is exceeded, the synchronous rectifier turns off, forcing the inductor current to flow through the high-side MOSFET body diode, back to the input, until the beginning of the next cycle or until the inductor current drops to zero. The AME5290 uses a pulse-skip mode to prevent overheating during short-circuit output conditions. The device enters pulse-skip mode when the FB voltage drops below 300mV, limiting the current to 4.5A (typ.) and reducing power dissipation. Normal operation resumes upon removal of the short-circuit condition.

Over Voltage Protection

The AME5290 monitors a resistor divided feedback voltage to detect over voltage. When the feedback voltage becomes higher than the target voltage for 12% (typ.), the OVP comparator output goes high and the circuit latches as the high-side MOSFET turned OFF and low-side MOSFET turned ON cycle by cycle.

Soft-Start

The AME5290 employ soft-start circuitry to reduce supply inrush current during startup conditions.

Thermal-Overload Protection

Thermal-overload protection limits total power dissipation in the device. When the junction temperature exceeds $T_J = +160^{\circ}\text{C}$, a thermal sensor forces the device into shutdown, allowing the die to cool. The thermal sensor turns the device on again after the junction temperature cools by 20°C , resulting in a pulsed output during continuous overload conditions.

Undervoltage Lockout

If VCC drops below 1.8V, the UVLO circuit inhibits switching. Once VCC rises above 2V, the UVLO clears, and the soft-start sequence activates.

Shutdown Mode

The EN pin has an internal pull high resistor connect to VCC. To shut down the AME5290, use an NPN bipolar junction transistor or a MOSFET to pull EN to GND. Shutdown mode causes the internal MOSFETs to stop switching, forces SW to a high-impedance state, and shorts REF to GND. Release EN to exit shutdown and initiate the soft-start sequence.

VCC Decoupling

Due to the high switching frequency and tight output tolerance, decouple VCC with a 0.1μF capacitor connected from VCC to GND, and a 10Ω resistor connected from VCC to VIN. Place the capacitor as close to VCC as possible.

■ Application Information

Inductor Selection

Use a 2μH inductor with a minimum 3A-rated DC current for most application. For best efficiency, use an inductor with a DC resistance of less than 20mΩ and a saturation current greater than 4A(min). For most designs, derive a reasonable inductor value (L_{INIT}) from the following equation: $L_{INIT} = V_{OUT} * (V_{IN} - V_{OUT}) / (V_{IN} * LIR * I_{OUT(MAX)} * f_{SW})$

where f_{SW} is the switching frequency (1MHz typ) of the oscillator. Keep the inductor current ripple percentage LIR between 20% and 40% of the maximum load current for the best compromise of cost, size, and performance. Calculate the maximum inductor current as:

$$I_{L(MAX)} = (1 + LIR / 2) * I_{OUT(MAX)}$$

Check the final values of the inductor with the output ripple voltage requirement. The output ripple voltage is given by:

$$V_{RIPPLE} = V_{OUT} * (V_{IN} - V_{OUT}) * ESR / (V_{IN} * L_{FINAL} * f_{SW})$$

Where ESR is the equivalent series resistance of the output capacitor.

Capacitor Selection

The input filter capacitor reduces peak currents drawn from the power source and reduces noise and voltage ripple on the input caused by the circuit's switching. The input capacitor must meet the ripple current requirement (I_{RMS}) imposed by the switching currents defined by the following equation:

$$I_{RMS} = (1 / V_{IN}) * (I_{OUT}^2 * V_{OUT} * (V_{IN} - V_{OUT}))^{1/2}$$

For duty ratios less than 0.5, the input capacitor RMS current is higher than the calculated current. Therefore, use a +20% margin when calculating the RMS current at lower duty cycles. Use ceramic capacitors for their low ESR, equivalent series inductance (ESL), and lower cost. Choose a capacitor that exhibits less than 10°C temperature rise at the maximum operating RMS current for optimum long-term reliability. After determining the input capacitor, check the input ripple voltage due to capacitor discharge when the high-side MOSFET turns on. Calculate the input ripple voltage as follows:

$$V_{IN_RIPPLE} = (I_{OUT} * V_{OUT}) / (f_{SW} * V_{IN} * C_{IN})$$

Keep the input ripple voltage less than 3% of the input voltage. The key selection parameters for the output capacitor are capacitance, ESR, ESL, and the voltage rating requirements. These affect the overall stability, output ripple voltage, and transient response of the DC-to-DC converter. The output ripple occurs due to variations in the charge stored in the output capacitor, the voltage drop due to the capacitor's ESR, and the voltage drop due to the capacitor's ESL. Calculate the output voltage ripple due to the output capacitance, ESR, and ESL as:

$$V_{\text{RIPPLE}} = V_{\text{RIPPLE(C)}} + V_{\text{RIPPLE(ESR)}} + V_{\text{RIPPLE(ESL)}}$$

where the output ripple due to output capacitance, ESR, and ESL is:

$$V_{\text{RIPPLE(C)}} = I_{\text{P-P}} / (8 \times C_{\text{OUT}} \times f_{\text{SW}})$$

$$V_{\text{RIPPLE(ESR)}} = I_{\text{P-P}} \times \text{ESR}$$

$$V_{\text{RIPPLE(ESL)}} = (I_{\text{P-P}} / t_{\text{ON}}) \times \text{ESL} \text{ or } (I_{\text{P-P}} / t_{\text{OFF}}) \times \text{ESL}$$

whichever is greater and $I_{\text{P-P}}$ the peak-to-peak inductor current is:

$$I_{\text{P-P}} = [(V_{\text{IN}} - V_{\text{OUT}}) / f_{\text{SW}} \times L] \times V_{\text{OUT}} / V_{\text{IN}}$$

Use these equations for initial capacitor selection, but determine final values by testing a prototype or evaluation circuit. As a rule, a smaller ripple current results in less output voltage ripple. Since the inductor ripple current is a factor of the inductor value, the output voltage ripple decreases with larger inductance. Use ceramic capacitors for their low ESR and ESL at the switching frequency of the converter. The low ESL of ceramic capacitors makes ripple voltages negligible. Load transient response depends on the selected output capacitor. During a load transient, the output instantly changes by $\text{ESR} \times I_{\text{LOAD}}$. Before the controller can respond, the output deviates further, depending on the inductor and output capacitor values. After a short time, the controller responds by regulating the output voltage back to its nominal state. The controller response time depends on the closed-loop bandwidth. A higher bandwidth yields a faster response time, thus preventing the output from deviating further from its regulating value.

Output Voltage Programming

The output voltage is set by resistive divider according to the following formula: $V_{\text{OUT}} = 0.8 \times (1 + R1/R2)$

Please keep R2 not larger than 25K Ω and select R1 using the formula.

Efficiency Considerations

Although all dissipative elements in the circuit produce losses, one major source usually account for most of the losses in AME5290 circuits: I^2R losses. The I^2R loss dominates the efficiency loss at medium to high load currents. The I^2R losses are calculated from the resistances of the internal switches, R_{SW} , and external inductor R_L . In continuous mode, the average output current flowing through inductor L is "chopped" between the main switch and the synchronous switch. Thus the series resistance looking into the SW pin is a function of both top and bottom MOSFET $R_{\text{DS(ON)}}$ and the duty cycle (D) as follows:

$$R_{\text{SW}} = (R_{\text{DS(ON)TOP}})(D) + (R_{\text{DS(ON)BOTTOM}})(1-D)$$

The $R_{\text{DS(ON)}}$ for both the top and bottom MOSFETs can be obtained from Electrical Characteristics table. Thus, to obtain I^2R losses, simply add R_{SW} to R_L and multiply the result by the square of the average output current. Other losses including C_{IN} and C_{OUT} ESR dissipative losses and inductor core losses generally account for less than 2% total additional loss.

Thermal Considerations

In most application the AME5290 does not dissipate much heat due to its high efficiency. But, in applications where the AME5290 is running at high ambient temperature with low supply voltage and high duty cycles, such as in dropout, the heat dissipated may exceed the maximum junction temperature of the part. If the junction temperature reaches approximately 150°C, both power switches will be turned off and the SW node will become high impedance.

Thermal performance can be improved with one of the following options:

- Increase the copper areas connected to GND, SW, and V_{IN}
- Provide thermal vias next to GND and V_{IN} , to the ground plane and power plane on the back side of PC board, with openings in the solder mask next to the vias to provide better thermal conduction.
- Provide forced-air cooling to further reduce case temperature

PC Board Layout Considerations

Careful PC board layout is critical to achieve clean and stable operation. The switching power stage requires particular attention. Follow these guidelines for good PC board layout:

- Place decoupling capacitors as close to the IC as possible. Keep power ground plane (connected to PGND) and signal ground plane (connected to GND) separate
- Connect input and output capacitors to the power ground plane; connect all other capacitors to the signal ground plane

Note:

Connect exposed pad (heat sink on the back) to GND.

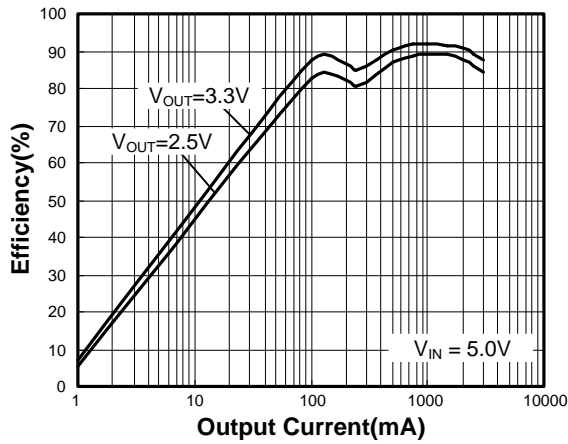
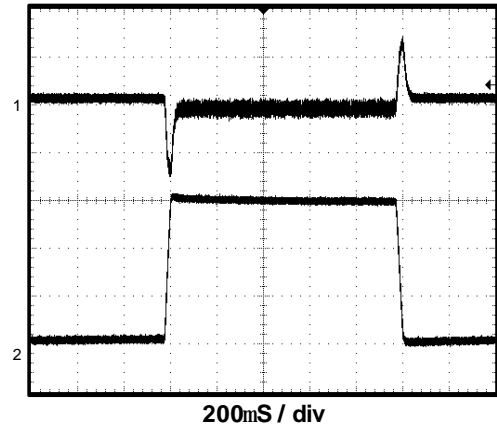
■ Characterization Curve
Efficiency vs. Output Current

Load Step

$V_{IN} = 5V$
 $V_{OUT} = 3.3V$
 $I_{OUT} = 5mA \sim 3A$
 $T_A = 25^{\circ}C$

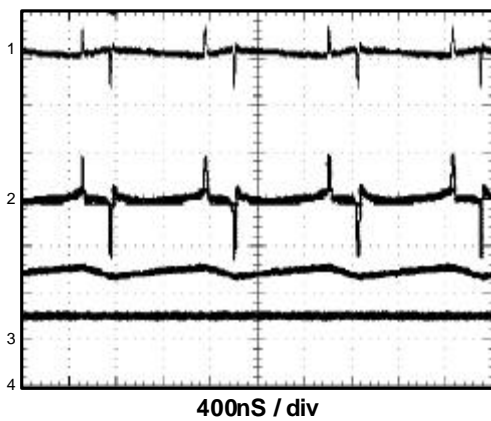
- 1) $V_{OUT} = 200mV/div$ (AC)
- 2) $I_{OUT} = 1A/div$

Output Voltage Ripple (Full Load)

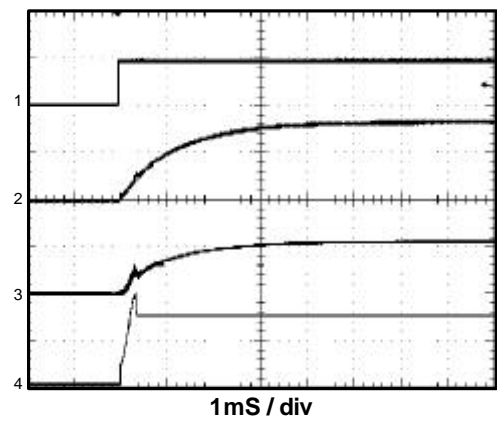
- 1) $V_{IN} = 500mV/div$
- 2) $V_{OUT} = 10mV/div$
- 3) $I_L = 2A/div$
- 4) $I_{OUT} = 2A/div$

Start-Up

- 1) $EN = 2V/div$
- 2) $V_{OUT} = 2V/div$
- 3) $I_{IN} = 2A/div$
- 4) $I_{OUT} = 2A/div$

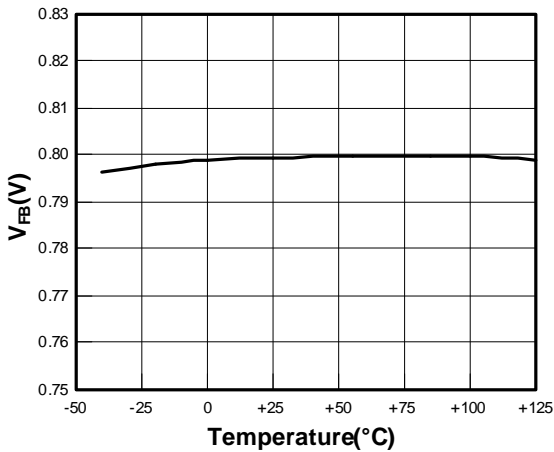
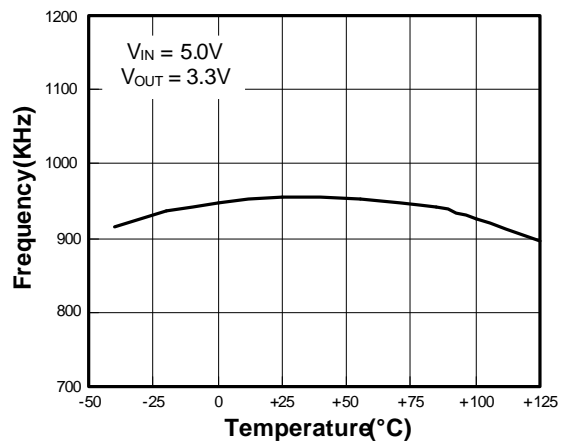
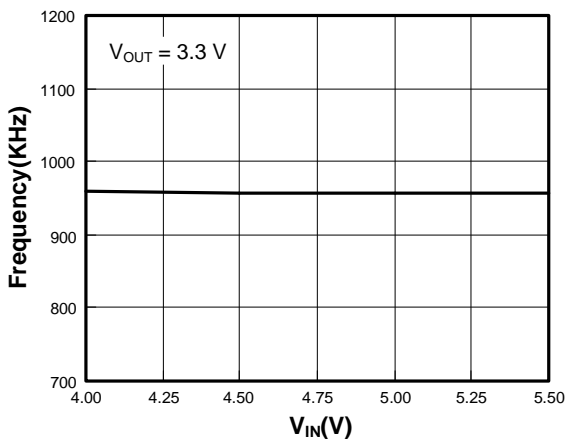
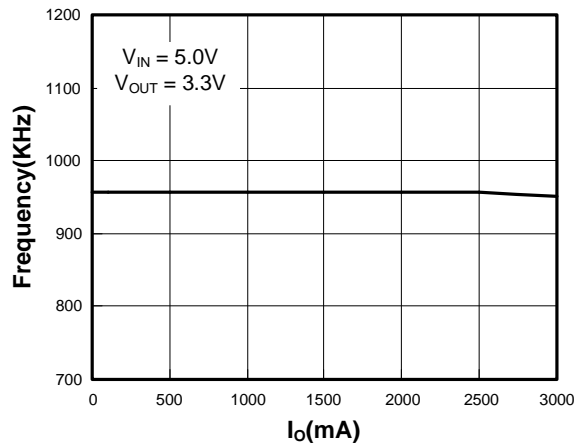
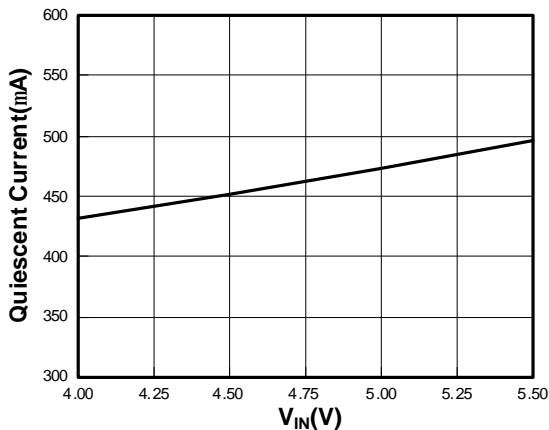
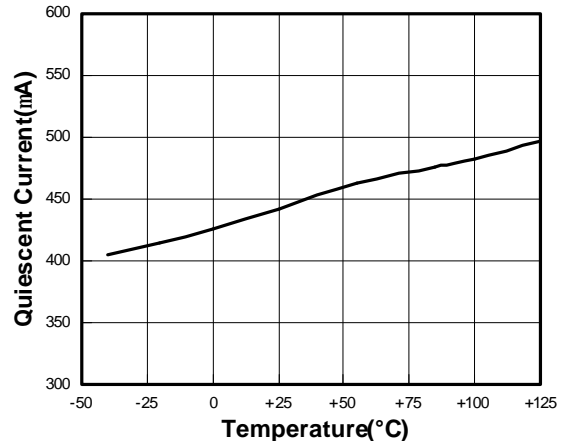
■ Characterization Curve (Contd.)
 V_{FB} vs. Temperature

Frequency vs. Temperature

Frequency vs. Supply Voltage

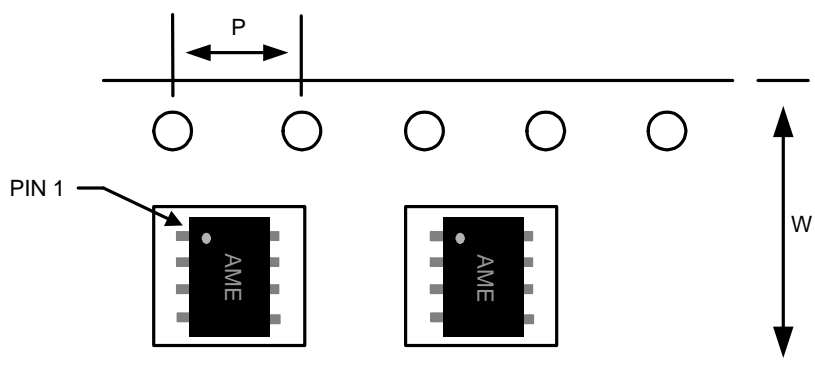
Frequency vs. Output Current

Quiescent Current (No Switching) vs. Input Voltage

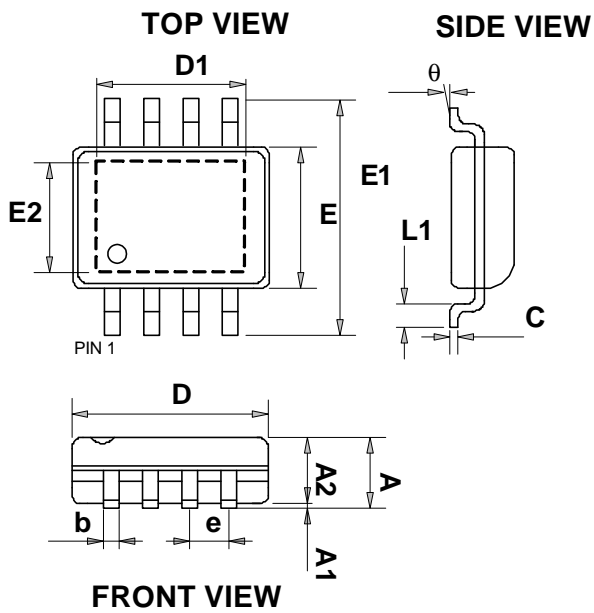
Quiescent Current (No Switching) vs. Temperature

■ Date Code Rule

Month Code	
1: January	7: July
2: February	8: August
3: March	9: September
4: April	A: October
5: May	B: November
6: June	C: December

■ Tape and Reel Dimension
SOP-8/PP

Carrier Tape, Number of Components Per Reel and Reel Size

Package	Carrier Width (W)	Pitch (P)	Part Per Full Reel	Reel Size
SOP-8/PP	12.0±0.1 mm	4.0±0.1 mm	2500pcs	330±1 mm

■ Package Dimension
SOP-8/PP

SYMBOLS	MILLIMETERS		INCHES	
	MIN	MAX	MIN	MAX
A	1.350	1.750	0.053	0.069
A1	0.000	0.150	0.000	0.006
A2	1.350	1.600	0.053	0.063
C	0.100	0.250	0.004	0.010
E	3.750	4.150	0.148	0.163
E1	5.700	6.300	0.224	0.248
L1	0.300	1.270	0.012	0.050
b	0.310	0.510	0.012	0.020
D	4.720	5.120	0.186	0.202
e	1.270 BSC		0.050 BSC	
q	0°	8°	0°	8°
E2	2.150	2.513	0.085	0.099
D1	2.150	3.402	0.085	0.134



www.ame.com.tw
E-Mail: sales@ame.com.tw

Life Support Policy:

These products of AME, Inc. are not authorized for use as critical components in life-support devices or systems, without the express written approval of the president of AME, Inc.

AME, Inc. reserves the right to make changes in the circuitry and specifications of its devices and advises its customers to obtain the latest version of relevant information.

© AME, Inc. , August 2011

Document: HU003-DS5290-B.01

Corporate Headquarter
AME, Inc.

8F-1, 12 WenHu St., Nei-Hu District

Taipei 114, Taiwan.

Tel: 886 2 2627-8687

Fax: 886 2 2659-2989