

■ General Description

The AME5297 is a high frequency synchronous stepdown DC-DC converter with built internal power MOSFETs. That provides wide 4.5V to 18V input voltage range and 3A continuous load current capability. The AME5297 has synchronous mode operation for higher efficiency over output current load range.

The AME5297 is current mode control scheme which provides fast transient reponse. Internal compensation function.

■ Features

- Wide 4.5V to 18V Operating Input Range
- 80mΩ/30mΩ Low $R_{DS(ON)}$ internal Power MOSFETs
- Proprietary Switching Loss Reduction Technique
- High Efficiency Synchronous Mode Operation
- Fixed 500KHz Switching Frequency
- External Programmable Soft Start
- OCP and Hiccup
- Thermal Shutdown
- Output Adjustable from 0.8V
- RoHS Compliant and Halogen Free

■ Application

- Notebook Systems and I/O Power
- Digital Set Top Boxes
- LCD Display, TV
- Networking, XDSL Modem

■ Typical Application

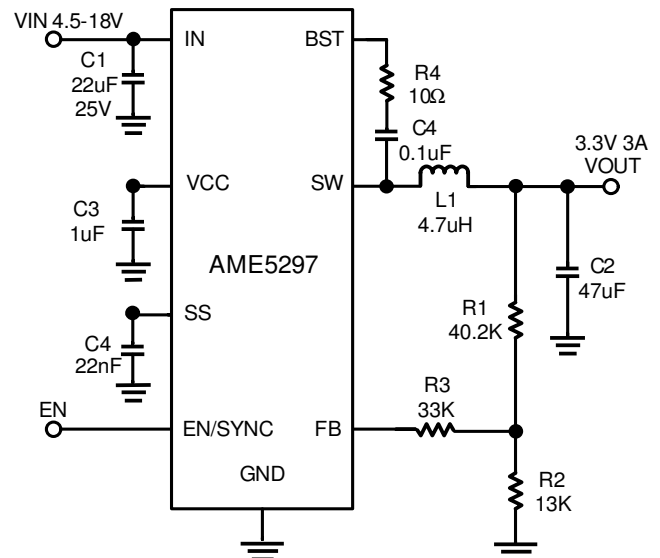

■ Functional Block Diagram

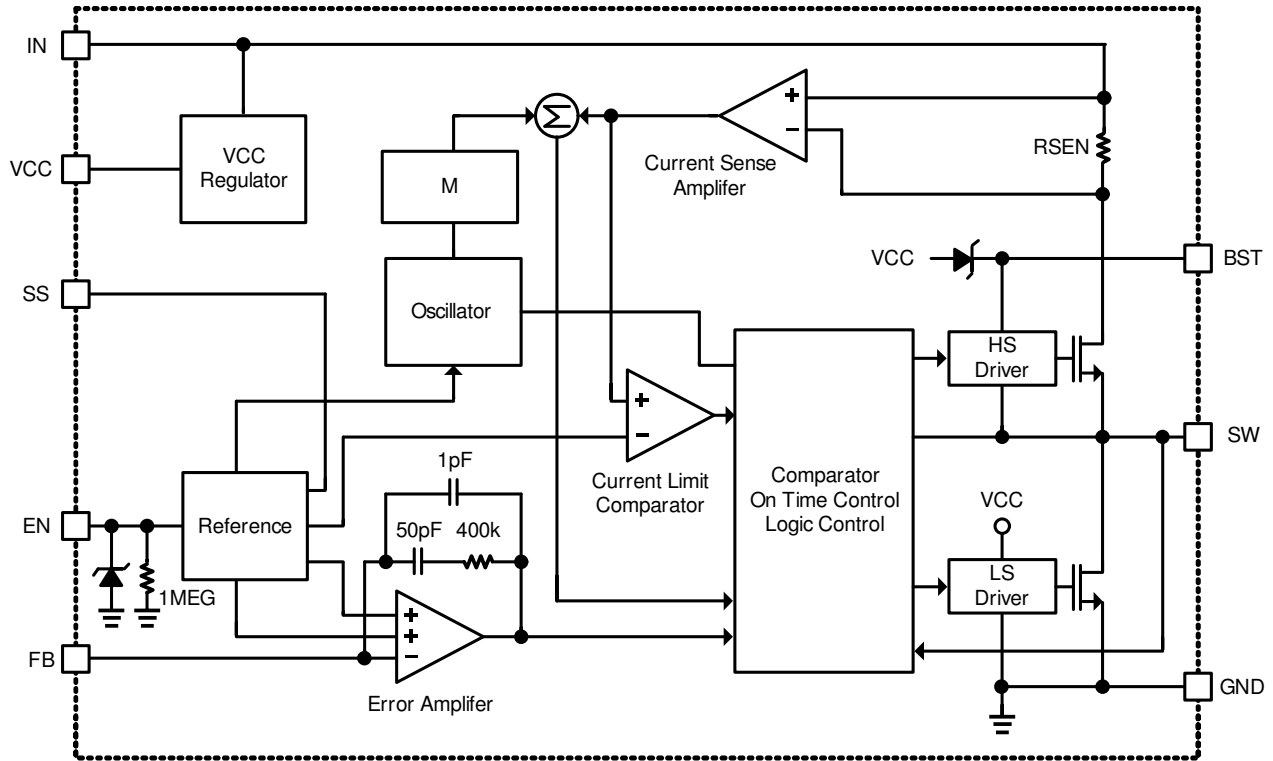

AME5297

■ Pin Configuration

TSOT-23-8
Top View

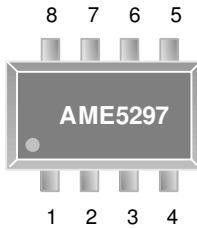

AME5297-AEAxxx

1. SS
2. IN
3. SW
4. GND
5. BST
6. EN
7. VCC
8. FB

*** Die Attach:
Conductive Epoxy**

■ Pin Description

Pin No.	Pin Name	Pin Description
1	SS	Soft-Start Control Input. SS controls the soft-start period. Connect a capacitor from SS to GND to set the soft-start period.
2	IN	Supply Voltage. The AME5297 operates from a +4.5V to +18V input rail. C1 is needed to decouple the input rail. Use wide PCB trace to make the connection.
3	SW	Switch Node. Connect this pin to an external L-C filter.
4	GND	System Ground. This pin is the reference ground of the regulated output voltage. For this reason care must be taken in PCB layout. Suggested to be connected to GND with copper and vias.
5	BST	Bootstrap for High Side Gate Driver. Connect a 0.1μF or greater ceramic capacitor from BST to SW pins.
6	EN	Enable. EN high to enable the AME5297.
7	VCC	Bias Supply. Decouple with a 1μF cap.
8	FB	Feedback Input. It's used to regulate the output of the converter to a set value via an external resistive voltage divider.

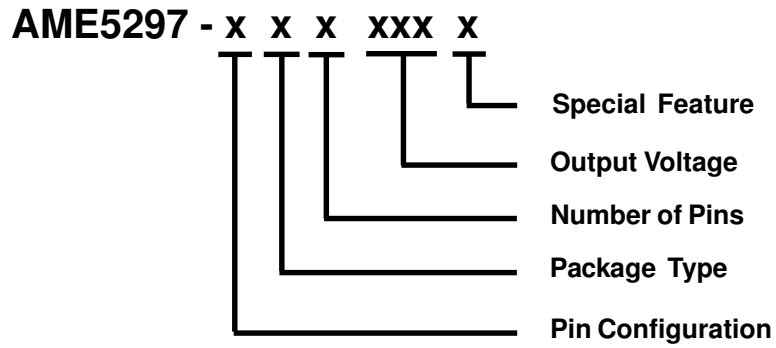
AME5297
■ Ordering Information

Pin Configuration	Package Type	Number of Pins	Output Voltage	Special Feature
A <small>(TSOT-23-8)</small> 1. SS 2. IN 3. SW 4. GND 5. BST 6. EN 7. VCC 8. FB	E: SOT-2X	A: 8	ADJ: Adjustable	L: TSOT-23-8 (Low Profile)

AME5297
■ Absolute Maximum Ratings

Parameter	Maximum	Unit
V_{IN}	-0.3 to 19	V
V_{SW}	-0.3V (-5V for 10ns) to 19V (20V for 5ns)	V
V_{BST}	$V_{SW}+6V$	V
All Other Pins	-0.3 to 6	V
Junction Temperature	150	°C
Lead Temperature	260	°C
Storage Temperature	-65 to +150	°C

■ Recommended Operating Conditions

Parameter	Symbol	Rating	Unit
Input Voltage	V_{IN}	4.5V to 18V	V
Output Voltage	V_{OUT}	0.8V to $V_{IN}-3V$	
Junction Temperature Range	T_J	-40 to +125	°C
Ambient Temperature Range	T_A	-40 to +85	

■ Thermal Information

Parameter	Package	Die Attach	Symbol	Maximum	Unit
Thermal Resistance* (Junction to Case)	TSOT-23-8	Conductive Epoxy	θ_{JC}	55	°C / W
Thermal Resistance (Junction to Ambient)			θ_{JA}	100	
Internal Power Dissipation			P_D	1250	mW
Lead Temperature (Soldering 10sec)**				260	°C

* Measure θ_{JC} on backside center of molding compound if IC has no tab.

** MIL-STD-202G210F

AME5297
■ Electrical Specifications

$V_{IN}=12V$, unless otherwise noted. Typical values are at $T_A=25^{\circ}C$.

Parameter	Symbol	Test Condition	Min	Typ	Max	Units
Supply Shutdown Current	I_{IN}	$V_{EN}=0V$		0.1		μA
Supply Current	I_Q	$V_{EN}=2V, V_{FB}=1V, V_{SS}=3V$		0.7		mA
High Side Switch On-Resistance	$R_{DS(ON)1}$	$V_{BST-SW}=5V$		80		m Ω
Low Side Switch On-Resistance	$R_{RDS(ON)2}$	$V_{CC}=5V$		30		m Ω
Load Side Switch Leakage Current	SW_{LKG}	$V_{EN}=0V, V_{SW}=12V$		0.15		μA
Switch Current Limit			4.2	5		A
Oscillator Frequency	f_{OSC}	$V_{FB}=0.75V$	440	500	580	KHz
Fold-back Frequency	f_{FB}	$V_{FB}<400mV$		0.25		f_{sw}
Maximum Duty Cycle	D_{MAX}	$V_{FB}=700mV$	90	95		%
Feedback Voltage	V_{FB}	$T_A=25^{\circ}C$	-2%	800	2%	mV
Feedback Current	I_{FB}	$V_{FB}=800mV$		10	50	nA
EN Rising Threshold	V_{EN_RISING}		1.2	1.4	1.6	V
EN Falling Threshold	$V_{EN_FALLING}$		1.1	1.25	1.4	V
EN Input Current	I_{EN}	$V_{EN}=2V$		2		μA
		$V_{EN}=0V$		0		μA
EN Turn Off Delay	EN_{TD-OFF}			8		μs
Input Under Voltage Lockout Threshold	V_{UVLO}			3.6		V
Input Under Voltage Lockout Hysteresis	ΔV_{UVLO}			650		mV
V_{CC} Regulator	V_{CC}			5		V
V_{CC} Load Regulation		$I_{CC}=5mA$		3		%
Soft-Start Current	I_{SS}			11		μA
Thermal Shutdown	T_{SD}			150		$^{\circ}C$
Thermal Hysteresis				20		$^{\circ}C$

■ Detailed Description

Internal V_{CC} Regulator

The internal V_{CC} regulator is adjusted 5.0V to provide power to the internal circuits from input voltage V_{IN} . In order to maintain the V_{CC} voltage stably, a 1 μ F ceramic capacitor is recommended.

Enable and Soft Start

The EN pin provides electrical on/off control of the regulator. When the EN pin voltage exceeds the lockout threshold voltage, the regulator starts to operate and the soft start begins to charge the external capacitor. If the EN pin voltage is pulled below the lockout threshold voltage, the regulator stops switching and the soft start resets. Connecting the EN pin to ground or to any voltage less than 1.2V will disable the regulator and activate the shutdown mode. To limit the start-up inrush current, a soft-start circuit is used to ramp up the reference voltage from 0V to its final value linearly. The soft start time can be calculated as follows:

$$t_{SS} = \frac{0.8 \times C_{SS}}{I_{SS}}$$

Under Voltage Lockout (UVLO)

The AME5297 incorporates an under voltage lockout circuit to keep the device disabled when the input voltage V_{IN} is below the UVLO start threshold voltage. During powering up, the internal circuits are held inactive and the soft start is grounded until the input voltage V_{IN} exceeds the UVLO start threshold voltage. Once the UVLO start threshold voltage is reached, the soft start is activated and the device begins to operate. The device operates until the input voltage V_{IN} falls below the UVLO stop threshold voltage. The typical hysteresis in the UVLO comparator is 650mV.

Thermal Shutdown

The AME5297 protects itself from overheating with an internal thermal shutdown circuit. If the junction temperature exceeds the thermal shutdown threshold, the voltage reference is grounded and the shutdown mode is activated. The AME5297 is restarted under control of the soft start automatically when the junction temperature drops 20°C below the thermal shutdown threshold.

Over-Current Protection and Hiccup Mode

The over-current limiting is implemented by cycle-by-cycle monitoring the current through the high side MOSFET. If the peak current exceeds the over-current limit threshold, the high side MOSFET is turned off. When the feedback voltage V_{FB} drops below 0.4V, the oscillator frequency is reduced to about 1/4 of the normal frequency to ensure that the inductor current has more time to decay, thereby preventing runaway. Meanwhile, the AME5297 enters hiccup mode, the average short circuit current is greatly reduced to alleviate the thermal issue and to protect the regulator.

External Bootstrap Circuit

The external bootstrap circuit contains a capacitor and a resistor. A bootstrap capacitor provides power for the high side MOSFET driver. In order to supply the AC current and maintain the BST-SW voltage stably at the switching condition of the high side MOSFET, a 0.1 μ F low ESR ceramic capacitor is recommended. The bootstrap resistor which suggests placing 10 Ω is utilized to reduce switching spike voltage and noise.

■ Application Information

Inductor Selection

For most applications, the inductance range is chosen based on the desired ripple current. A larger inductance reduces ripple current; meanwhile, the output ripple voltage decreases. Determine inductance is to allow the peak-to-peak ripple current to be approximately 30% of the maximum load current. The inductance value can be calculated by:

$$L = \frac{V_{OUT}}{f \times \Delta I_L} \times \left(1 - \frac{V_{OUT}}{V_{IN}}\right)$$

Where f is the oscillator frequency, V_{IN} is the input voltage, V_{OUT} is the output voltage, and ΔI_L is the peak-to-peak inductor ripple current. Choose an inductor that will not saturate under the maximum inductor peak current, calculated by:

$$I_{LPEAK} = I_{LOAD} + \frac{V_{OUT}}{2 \times f \times \Delta I_L} \times \left(1 - \frac{V_{OUT}}{V_{IN}}\right)$$

Where I_{LOAD} is the load current. The choice of which style inductor to use mainly depends on the price vs. size requirements and any EMI constraints.

Input Capacitor

The input current to the buck converter is discontinuous; therefore an input capacitor is required to supply the AC current while maintaining the DC input voltage. In order to prevent large voltage drop, a low ESR capacitors is recommended for the best performance. Ceramic capacitors are preferred, but tantalum or low-ESR electrolytic capacitors will also be suggested. Choose X5R or X7R dielectrics when using ceramic capacitors. Since the input capacitor absorbs the input switching current, it requires an adequate ripple current rating. The RMS current in the input capacitor can be estimated by:

$$I_{CIN} = I_{LOAD} \times \sqrt{\frac{V_{OUT}}{V_{IN}} \times \left(1 - \frac{V_{OUT}}{V_{IN}}\right)}$$

At $V_{IN} = 2V_{OUT}$, where $I_{CIN} = I_{LOAD}/2$ is the worst-case condition occurs. For simplification, use an input capacitor with a RMS current rating greater than half of the maximum load current. When using ceramic capacitors, make sure that they have enough capacitance to provide sufficient charge to prevent excessive voltage ripple at input. When using electrolytic or tantalum capacitors, a high quality, small ceramic capacitor, i.e. 0.1 μ F, should be placed as close to the IC as possible. The input voltage ripple for low ESR capacitors can be estimated by:

$$\Delta V_{IN} = \frac{I_{LOAD}}{C_{IN} \times f} \times \frac{V_{OUT}}{V_{IN}} \times \left(1 - \frac{V_{OUT}}{V_{IN}}\right)$$

Where C_{IN} is the input capacitance value.

Output Capacitor

The output capacitor (C_{OUT}) is required to maintain the DC output voltage. Ceramic, tantalum, or low ESR electrolytic capacitors are recommended. Low ESR capacitors are preferred to keep the output voltage ripple low. The output voltage ripple can be estimated by:

$$\Delta V_{OUT} = \frac{V_{OUT}}{f \times L} \times \left(1 - \frac{V_{OUT}}{V_{IN}}\right) \times \left(R_{ESR} + \frac{1}{8 \times f \times C_{OUT}}\right)$$

Where R_{ESR} is the equivalent series resistance (ESR) value of the output capacitor and C_{OUT} is the output capacitance value.

When using ceramic capacitors, the impedance at the switching frequency is dominated by the capacitance which is the main cause for the output voltage ripple. For simplification, the output voltage ripple can be estimated by:

$$\Delta V_{OUT} = \frac{V_{OUT}}{8 \times f^2 \times L \times C_{OUT}} \times \left(1 - \frac{V_{OUT}}{V_{IN}}\right)$$

AME5297

When using tantalum or electrolytic capacitors, the ESR dominates the impedance at the switching frequency. For simplification, the output ripple can be approximated to:

$$\Delta V_{OUT} = \frac{V_{OUT}}{f \times L} \times \left(1 - \frac{V_{OUT}}{V_{IN}}\right) \times R_{ESR}$$

Setting the Output Voltage

The output voltage is using a resistive voltage divider connected from the output voltage to feedback pin. It divides the output voltage down to the feedback voltage by the ratio:

$$V_{FB} = V_{OUT} \times \frac{R_2}{R_1 + R_2}$$

The output voltage is:

$$V_{OUT} = 0.8 \times \frac{R_1 + R_2}{R_2}$$

■ Typical Application Circuits

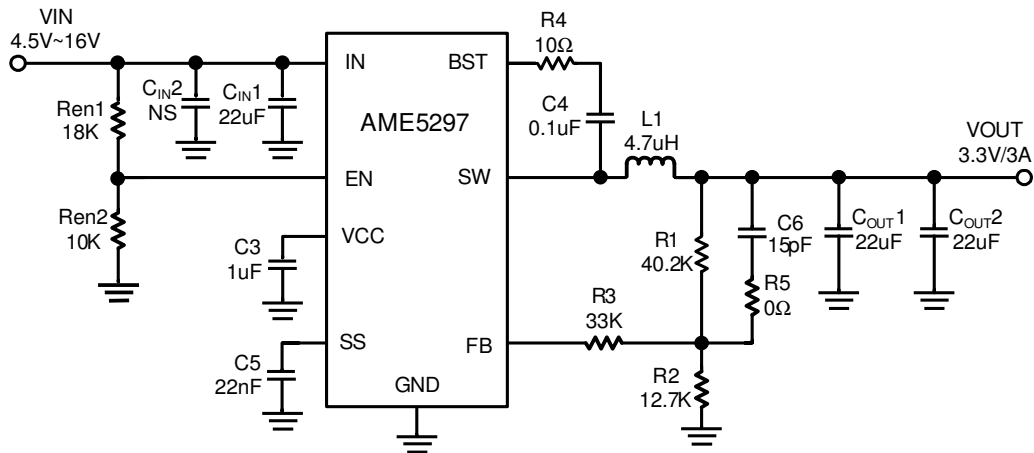

V _{OUT} (V)	R1(KΩ)	R2(KΩ)	R3(KΩ)	L(μH)	C _{IN} (μF)	C _{OUT} (μF)
1.0	20.5	82.0	82	1.5	22	22x2
1.2	30.1	60.4	82	1.5	22	22x2
1.8	40.2	32.4	56	2.2	22	22x2
2.5	40.2	19.1	33	3.3	22	22x2
3.3	40.2	12.7	33	4.7	22	22x2
5.0	40.2	7.68	33	6.8	22	22x2

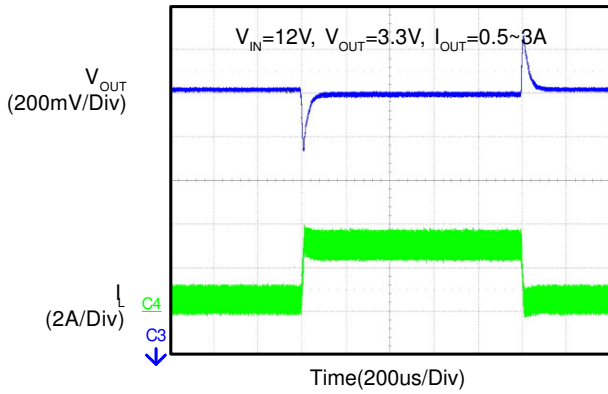
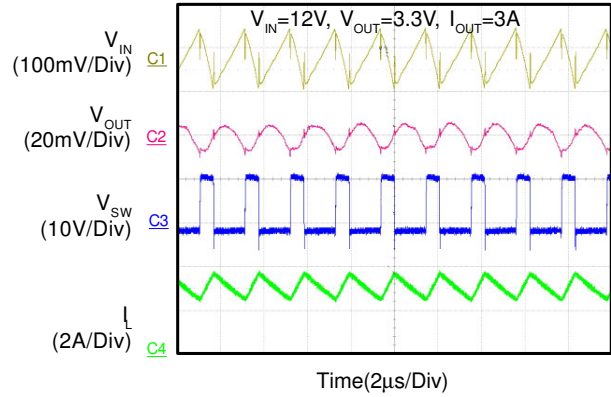
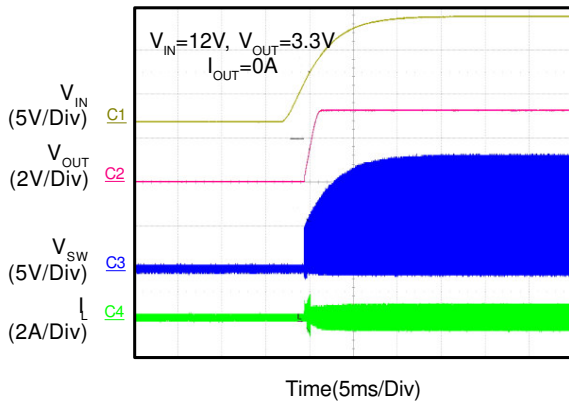
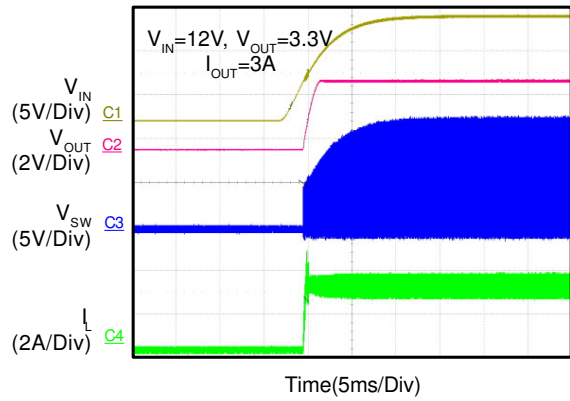
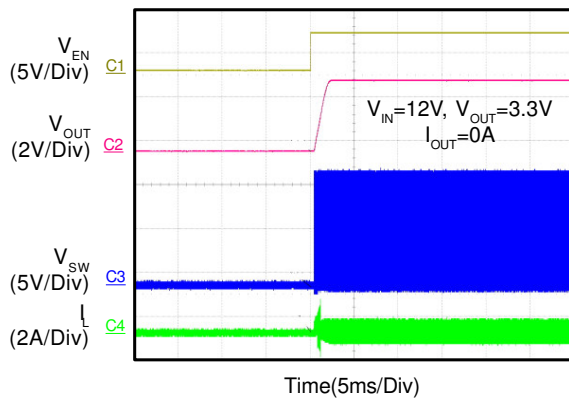
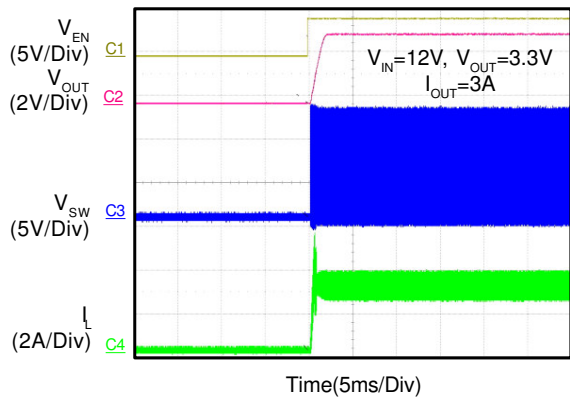
■ Characterization Curve
Load Transient

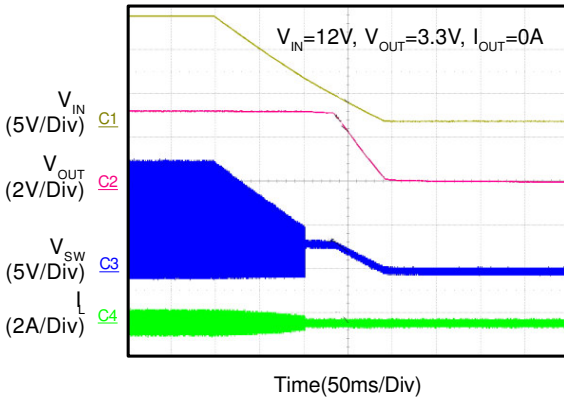
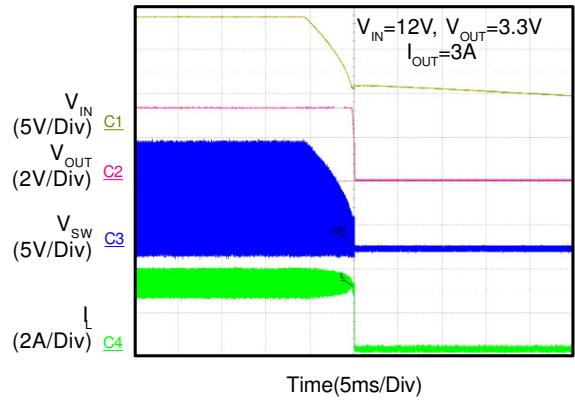
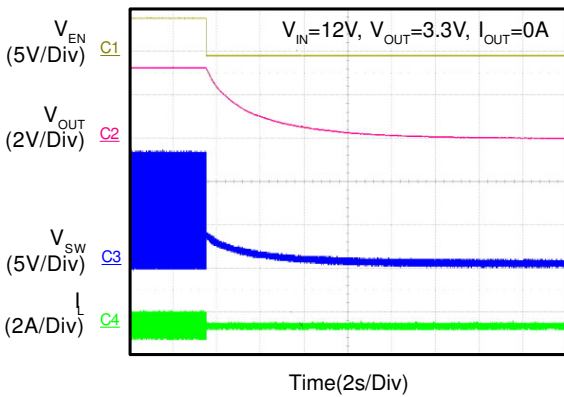
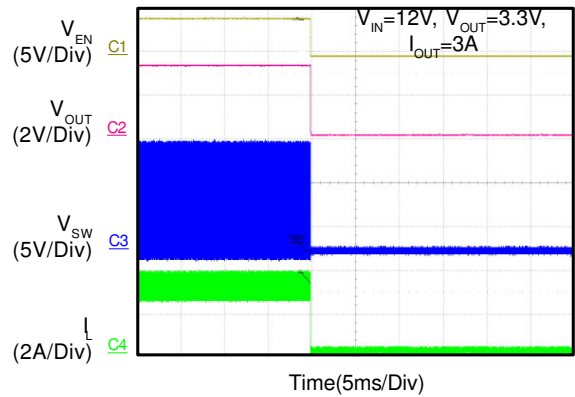
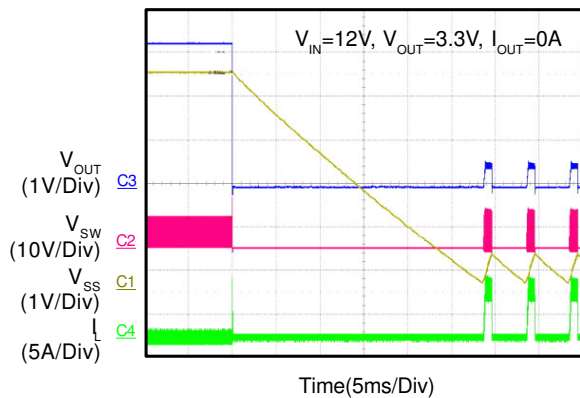
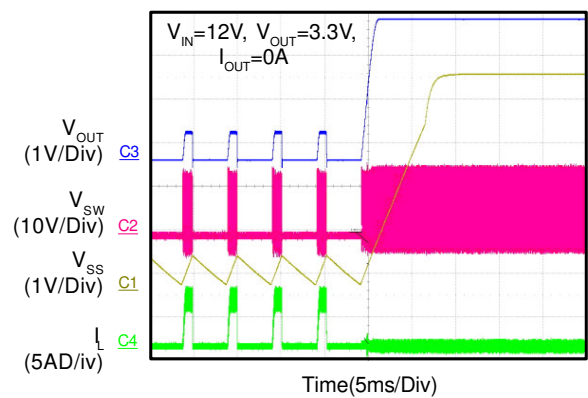
Output Voltage Ripple

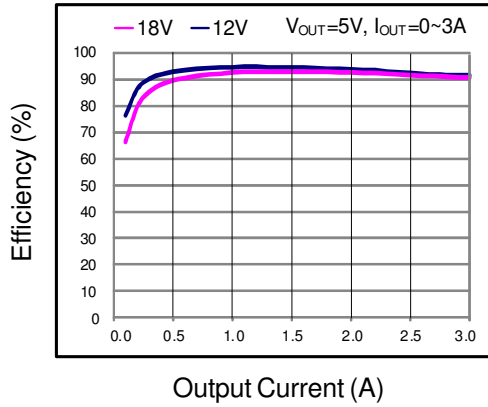
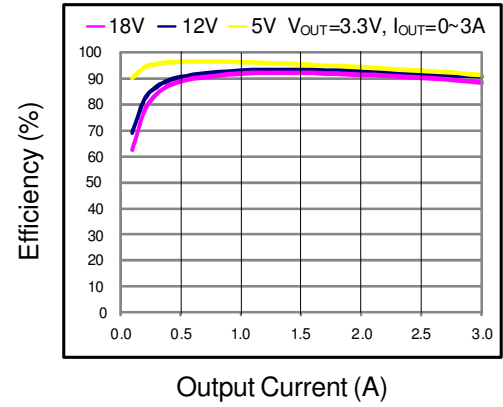
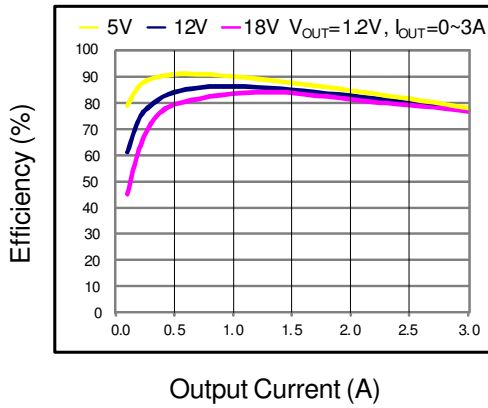
Power On from Input Voltage

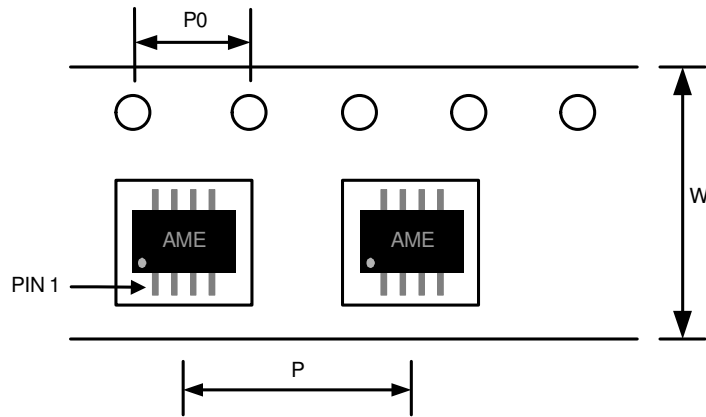
Power On from Input Voltage

Power On from EN

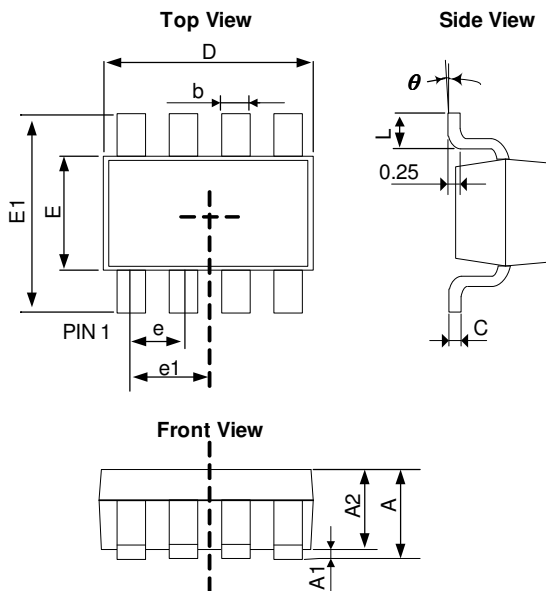
Power on from EN

Power Off from Input Voltage

Power Off from Input Voltage

Power Off from EN

Power Off from EN

Short Circuit Entry

Short Circuit Recovery

Efficiency

Efficiency

Efficiency

AME5297
■ Tape and Reel Dimension
TSOT-23-8

Carrier Tape, Number of Components Per Reel and Reel Size

Package	Carrier Width (W)	Pitch (P)	Pitch (P0)	Part Per Full Reel	Reel Size
TSOT-23-8	8.0±0.1 mm	4.0±0.1 mm	4.0±0.1 mm	3000pcs	180±1 mm

■ Package Dimension
TSOT-23-8

SYMBOLS	MILLIMETERS		INCHES	
	MIN	MAX	MIN	MAX
A	0.70	0.90	0.028	0.035
A1	0.00	0.10	0.000	0.004
A2	0.70	0.80	0.028	0.031
b	0.30	0.50	0.012	0.020
c	0.08	0.20	0.003	0.008
D	2.82	3.02	0.111	0.119
E	1.60	1.70	0.063	0.067
E1	2.65	2.95	0.104	0.116
e	0.65 (BSC)		0.026 (BSC)	
e1	0.975 (BSC)		0.038 (BSC)	
L	0.30	0.60	0.012	0.024
θ	0°	8°	0°	8°



www.ame.com.tw
E-Mail: sales@ame.com.tw

Life Support Policy:

These products of AME, Inc. are not authorized for use as critical components in life-support devices or systems, without the express written approval of the president of AME, Inc.

AME, Inc. reserves the right to make changes in the circuitry and specifications of its devices and advises its customers to obtain the latest version of relevant information.

© AME, Inc. , May 2016

Document: A018A-DS5297-A.07

Corporate Headquarter
AME, Inc.

8F, 12, WenHu St., Nei-Hu
Taipei 114, Taiwan .
Tel: 886 2 2627-8687
Fax: 886 2 2659-2989