

## ■ General Description

The AME8804 family of positive, linear regulators feature low ground current (35µA typ.) with low dropout voltage, making them ideal for battery applications. The space-saving SOT-26/TSOT-26 and SOT-25/TSOT-25 packages are attractive for "Pocket" and "Hand Held" applications.

These rugged devices have both Thermal Shutdown, and Current Fold-back to prevent device failure under the "Worst" operating conditions.

The SOT-26/TSOT-26 version also features a "Power Good" detector, which pulls low when the output is out of regulation.

The AME8804 is stable with an output capacitance of 2.2µF or greater.

## ■ Features

- Very Low Dropout Voltage
- Guaranteed 300mA Output
- Accurate to within 1.5%
- Typical 35µA Ground Current
- Over-Temperature Shutdown
- Current Limiting
- Short Circuit Current Fold-back
- Power Good Detector (6 pin version only)
- Power-Saving Shutdown Mode
- Space-Saving SOT-26/TSOT-26 and SOT-25 / TSOT-25
- Adjustable Output Voltages
- Low Temperature Coefficient
- All AME's Lead Free Products Meet RoHS Standards

## ■ Applications

- Instrumentation
- Portable Electronics
- Wireless Devices
- Cordless Phones
- PC Peripherals
- Battery Powered Widgets
- Electronic Scales

## ■ Functional Block Diagram

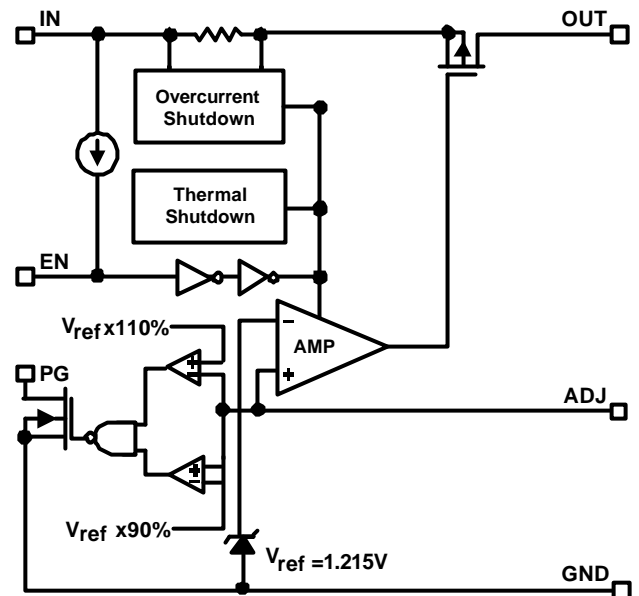

## ■ Typical Application

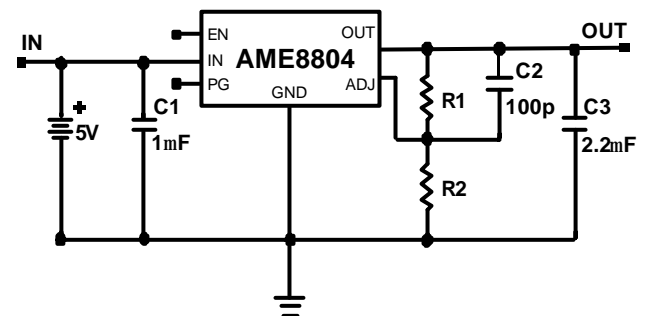

$$V_{OUT} = 1.215 (R1 + R2) / R2$$

C2 is unnecessary when R1 or R2 < 20K

PG pin is only available in the SOT-26 package option

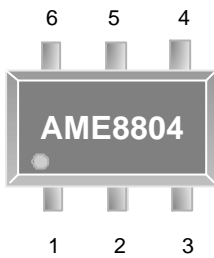
**■ Pin Configuration**
**SOT-26/TSOT-26  
Top View**

**AME8804AEEY**

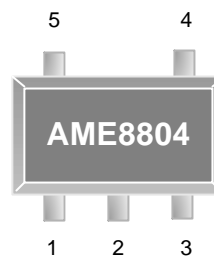
1. IN
2. GND
3. EN
4. PG
5. ADJ
6. OUT

**SOT-25 /TSOT-25  
Top View**

**AME8804AEEV**

1. IN
2. GND
3. EN
4. ADJ
5. OUT

**\* Die Attach:**  
**Non-Conductive Epoxy**

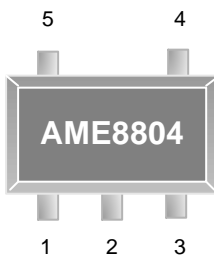
**\* Die Attach:**  
**Conductive Epoxy**

**SOT-25 /TSOT-25  
Top View**

**AME8804BEEVADJ**

1. EN
2. GND
3. IN
4. OUT
5. ADJ

**\* Die Attach:**  
**Conductive Epoxy**

**■ Pin Description**

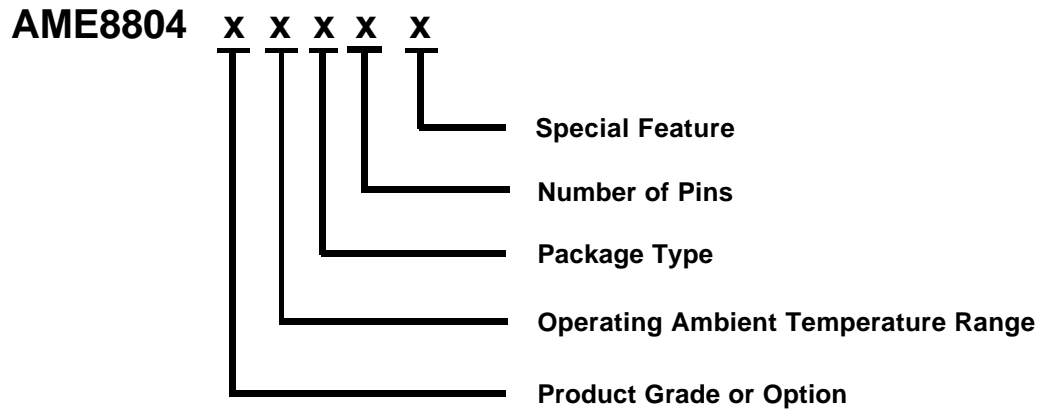
Pin Name	Pin Description
IN	Input voltage pin. It should be decoupled with 1 $\mu$ F or greater capacitor.
GND	Ground connection pin.
EN	Enable pin. When pulled low, the PMOS pass transistor turns off, current consuming less than 1 $\mu$ A.
PG	Power-Good output. This open-drain output is low when OUT is out of regulation.
OUT	LDO voltage regulator output pin. It should be decoupled with a 1 $\mu$ F or greater value low ESR ceramic capacitor.
ADJ	Feedback output voltage for adjustable device.

**■ Ordering Information**

Product Grade or Option	Operating Ambient Temperature Range	Package Type	Number of Pins	Special Feature
A: ADJ	E: -40°C to +85°C	E: SOT-2X	V: 5 Y: 6	L: Low Profile Y: Lead Free & Low Profile Z: Lead Free

**■ Ordering Information**

Part Number	Marking*	Output Voltage	Package	Operating Ambient Temperature Range
AME8804AEEY	AAUww	Adjustable	SOT-26	- 40°C to +85°C
AME8804AEEYL	AAUww	Adjustable	TSOT-26	- 40°C to +85°C
AME8804AEEYY	AAUww	Adjustable	TSOT-26	- 40°C to +85°C
AME8804AEEYZ	AAUww	Adjustable	SOT-26	- 40°C to +85°C
AME8804AEEV	AJCww	Adjustable	SOT-25	- 40°C to +85°C
AME8804AEEVL	AJCww	Adjustable	TSOT-25	- 40°C to +85°C
AME8804AEEVY	AJCww	Adjustable	TSOT-25	- 40°C to +85°C
AME8804AEEVZ	AJCww	Adjustable	SOT-25	- 40°C to +85°C

Note: ww represents the date code and pls refer to Date Code Rule on Package Dimension.

\* A line on top of the first letter represents lead free plating such as AAUww

Please consult AME sales office or authorized Rep./Distributor for output voltage and package type availability.

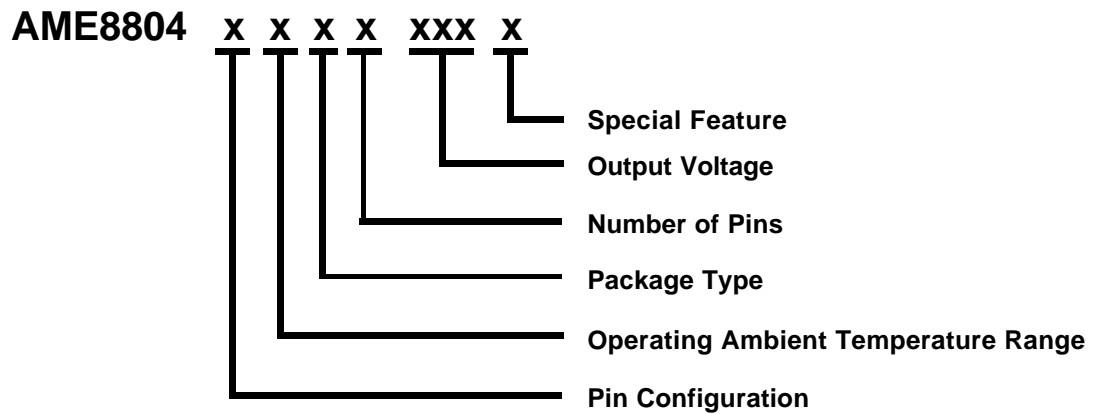
**■ Ordering Information (contd.)**

Pin Configuration	Operating Ambient Temperature Range	Package Type	Number of Pins	Output Voltage	Special Feature
B: 1. EN (SOT-25) 2. GND (TSOT-25) 3. IN 4. OUT 5. ADJ	E: -40°C to +85°C	E: SOT-2X	V: 5	ADJ: Adjustable	Z: Lead Free Y: Lead Free & Low Profile

**■ Ordering Information**

Part Number	Marking*	Output Voltage	Package	Operating Ambient Temperature Range
AME8804BEEVADJZ	BJlww	Adjustable	SOT-25	- 40°C to +85°C
AME8804BEEVADJY	BJlww	Adjustable	TSOT-25	- 40°C to +85°C

Note: ww represents the date code and pls refer to Date Code Rule on Package Dimension.

\* A line on top of the first letter represents lead free plating such as BJlww

Please consult AME sales office or authorized Rep./Distributor for output voltage and package type availability.

**■ Absolute Maximum Ratings**

Parameter	Maximum	Unit
Input Voltage	-0.3 to +8	V
EN Voltage	-0.3 to +8	V
Output Voltage	-0.3 to $V_{IN} + 0.3$	V
PG Voltage	-0.3 to $V_{IN} + 0.3$	V
Output Current	$P_D / (V_{IN} - V_{OUT})$	mA
ESD Classification	B*	

Caution: Stress above the listed absolute maximum rating may cause permanent damage to the device.

\* HBM B:2000V~3999V

**■ Recommended Operating Conditions**

Parameter	Symbol	Rating	Unit
Ambient Temperature Range	$T_A$	- 40 to +85	°C
Junction Temperature Range	$T_J$	- 40 to +125	°C
Storage Temperature Range	$T_{STG}$	- 65 to +150	°C

**■ Thermal Information**

Parameter	Package	Die Attach	Symbol	Maximum	Unit
Thermal Resistance* (Junction to Case)	SOT-25 TSOT-25	Conductive Epoxy	$\theta_{JC}$	81	°C / W
	SOT-26 TSOT-26	Non-Conductive Epoxy		140	
Thermal Resistance (Junction to Ambient)	SOT-25 TSOT-25	Conductive Epoxy	$\theta_{JA}$	260	
	SOT-26 TSOT-26	Non-Conductive Epoxy		280	
Internal Power Dissipation	SOT-25 TSOT-25	Conductive Epoxy	$P_D$	400	mW
	SOT-26 TSOT-26	Non-Conductive Epoxy		400	
Maximum Junction Temperature				150	°C
Solder Iron (10 Sec)**				350	°C

\* Measure  $\theta_{JC}$  on center of molding compound if IC has no tab.

\*\* MIL-STD-202G 210F

**■ Electrical Specifications**

 TA = 25°C, V<sub>IN</sub>=5V unless otherwise noted

Parameter	Symbol	Test Condition	Min	Typ	Max	Units
Input Voltage	V <sub>IN</sub>		Note 1		7	V
Output Voltage Accuracy	V <sub>O</sub>	I <sub>O</sub> =1mA	-1.5		1.5	%
Dropout Voltage	V <sub>DROPOUT</sub>	I <sub>O</sub> =300mA V <sub>O</sub> =V <sub>O(NOM)</sub> -2.0%	1.5V<V <sub>O(NOM)</sub> <=2.0V	See chart	1300	mV
			2.0V<V <sub>O(NOM)</sub> <=2.8V		400	
			2.8V<V <sub>O(NOM)</sub> <3.8V		300	
Output Current	I <sub>O</sub>	V <sub>O</sub> >1.2V	300			mA
Current Limit	I <sub>LIM</sub>	V <sub>O</sub> >1.2V	300	450		mA
Short Circuit Current, Note2	I <sub>SC</sub>	V <sub>O</sub> <0.8V		150	300	mA
Ground Pin Current	I <sub>GND</sub>	I <sub>O</sub> =1mA to 300mA		35		μA
Line Regulation	REG <sub>LINE</sub>	I <sub>O</sub> =5mA V <sub>IN</sub> =V <sub>O</sub> +1 to V <sub>O</sub> +2	V <sub>O</sub> < 2.0V		0.15	%
			V <sub>O</sub> >= 2.0V		0.02	0.1
Load Regulation	REG <sub>LOAD</sub>	I <sub>O</sub> =1mA to 300mA		0.2	1	%
Over Temperature Shutdown	OTS			150		°C
Over Temperature Hysteresis	OTH			30		°C
V <sub>O</sub> Temperature Coefficient	TC			30		ppm/°C
Power Supply Rejection	PSRR	I <sub>O</sub> =100mA C <sub>O</sub> =2.2μF	f=100Hz		60	dB
			f=1kHz		50	
			f=10kHz		20	
Output Voltage Noise	eN	f=10Hz to 100kHz I <sub>O</sub> =10mA, C <sub>BYP</sub> =0μF			30	μVrms
ADJ Input Bias Current	I <sub>ADJ</sub>			1		μA
ADJ Reference Voltage	V <sub>REF</sub>		1.2	1.215	1.23	V
EN Input Threshold	V <sub>EH</sub>	V <sub>IN</sub> =2.7V to 7V	2.0		V <sub>IN</sub>	V
	V <sub>EL</sub>	V <sub>IN</sub> =2.7V to 7V	0		0.4	V
EN Input Bias Current	I <sub>EH</sub>	V <sub>EN</sub> =V <sub>IN</sub> , V <sub>IN</sub> =2.7V to 7V			0.1	μA
	I <sub>EL</sub>	V <sub>EN</sub> =0V, V <sub>IN</sub> =2.7V to 7V			0.5	μA
Shutdown Supply Current	I <sub>SD</sub>	V <sub>IN</sub> =5V, V <sub>O</sub> =0V, V <sub>EN</sub> <V <sub>EL</sub>		0.5	1	μA
Shutdown Output Voltage	V <sub>O,SD</sub>	I <sub>O</sub> =35μA, V <sub>EN</sub> <V <sub>EL</sub>	0		0.1	V
Output Under Voltage	V <sub>UV</sub>				85	%V <sub>O(NOM)</sub>
Output Over Voltage	V <sub>OV</sub>		115			%V <sub>O(NOM)</sub>
PG Leakage Current	I <sub>LC</sub>	V <sub>PG</sub> =7V			1	μA
PG Voltage Rating	V <sub>PG</sub>	V <sub>O</sub> in regulation			7	V
PG Voltage Low	V <sub>OL</sub>	I <sub>SINK</sub> =0.4mA			0.4	V

 Note1: V<sub>IN(MIN)</sub>=V<sub>OUT</sub>+V<sub>DROPOUT</sub>

Note2: To prevent the Short Circuit Current protection feature from being prematurely activated, the input voltage must be applied before a current source load is applied.

## ■ Detailed Description

The AME8804 family of CMOS regulators contain a PMOS pass transistor, voltage reference, error amplifier, over-current protection, thermal shutdown, and Power Good detection circuitry.

The P-channel pass transistor receives data from the error amplifier, over-current shutdown, and thermal protection circuits. During normal operation, the error amplifier compares the output voltage to a precision reference. Over-current and Thermal shutdown circuits become active when the junction temperature exceeds 150°C, or the current exceeds 300mA. During thermal shutdown, the output voltage remains low. Normal operation is restored when the junction temperature drops below 120°C.

The AME8804 switches from voltage mode to current mode when the load exceeds the rated output current. This prevents over-stress. The AME8804 also incorporates current foldback to reduce power dissipation when the output is short circuited. This feature becomes active when the output drops below 0.8volts, and reduces the current flow by 65%. Full current is restored when the voltage exceeds 0.8 volts.

## ■ External Capacitors

The AME8804 is stable with an output capacitor to ground of 2.2 $\mu$ F or greater. Ceramic capacitors have the lowest ESR, and will offer the best AC performance. Conversely, Aluminum Electrolytic capacitors exhibit the highest ESR, resulting in the poorest AC response. Unfortunately, large value ceramic capacitors are comparatively expensive. One option is to parallel a 0.1 $\mu$ F ceramic capacitor with a 10 $\mu$ F Aluminum Electrolytic. The benefit is low ESR, high capacitance, and low overall cost.

A second capacitor is recommended between the input and ground to stabilize  $V_{in}$ . The input capacitor should be at least 0.1 $\mu$ F to have a beneficial effect.

All capacitors should be placed in close proximity to the pins. A "Quiet" ground termination is desirable. This can be achieved with a "Star" connection.

## ■ Enable

The Enable pin normally floats high. When actively, pulled low, the PMOS pass transistor shuts off, and all internal circuits are powered down. In this state, the quiescent current is less than 1 $\mu$ A. This pin behaves much like an electronic switch.

## ■ Power Good

The AME8804 (SOT-26/TSOT-26 package only) includes the Power Good feature. When the output is not within  $\pm 10\%$  of the specified voltage, it pulls low. This can occur under the following conditions:

- 1) Input Voltage too low.
- 2) During Over-Temperature.
- 3) During Over-Current.
- 4) If output is pulled up.

*(Note: PG pin is an open-drain output.)*

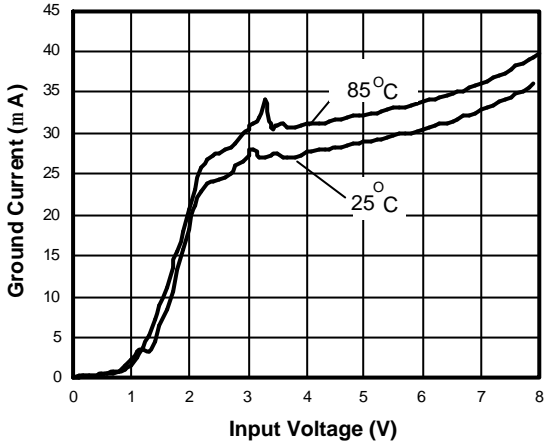
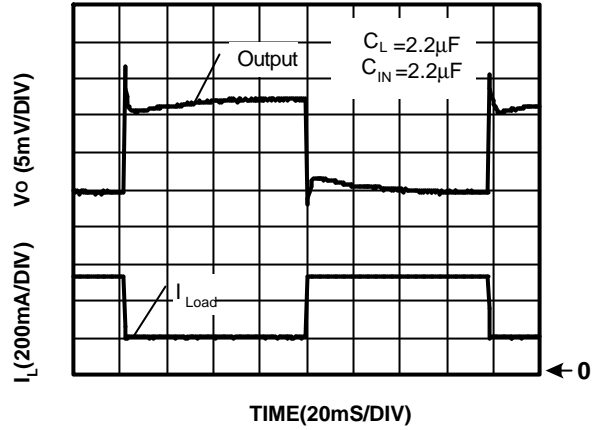
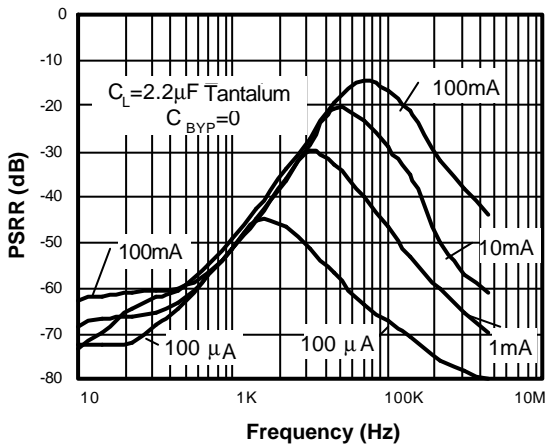
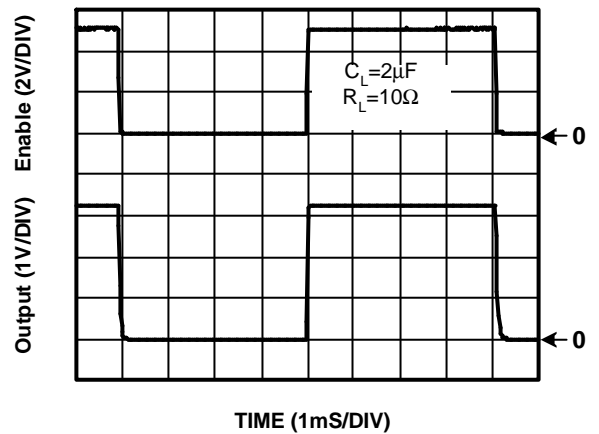
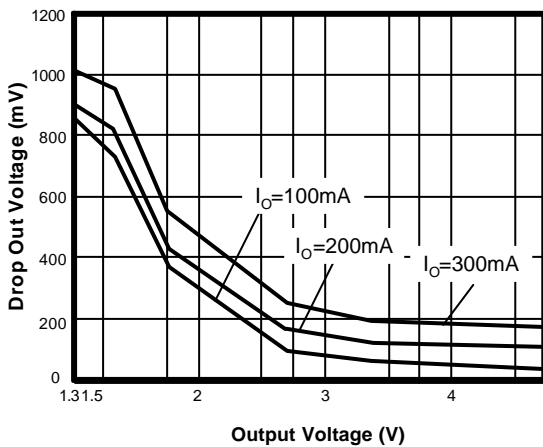
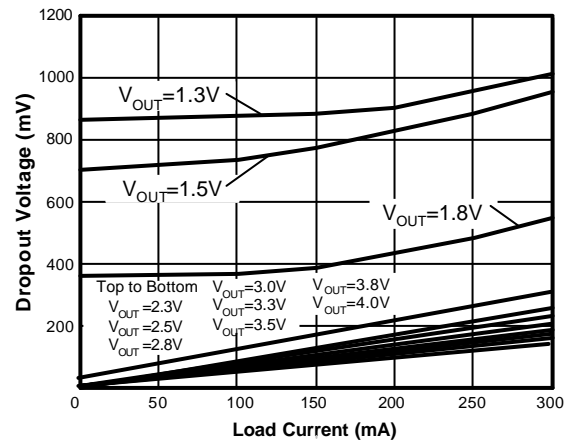
**Ground Current vs. Input Voltage**

**Load Step (1mA-300mA)**

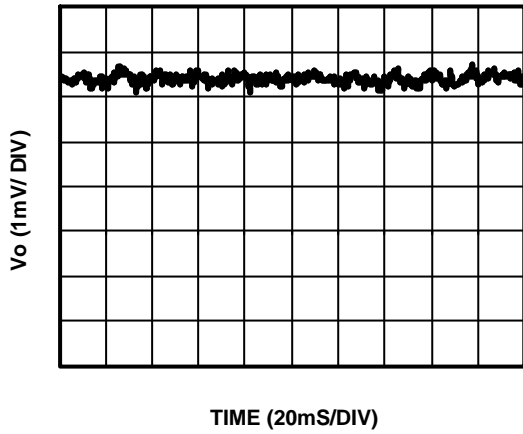
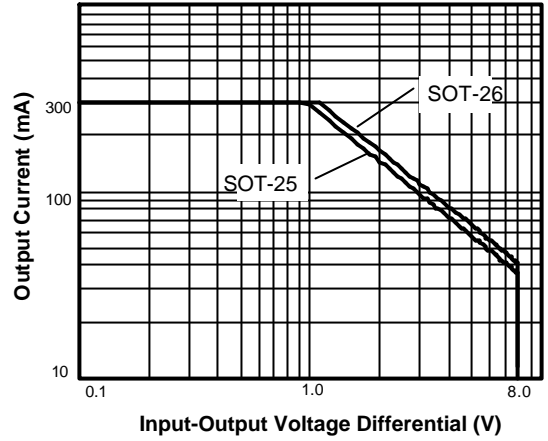
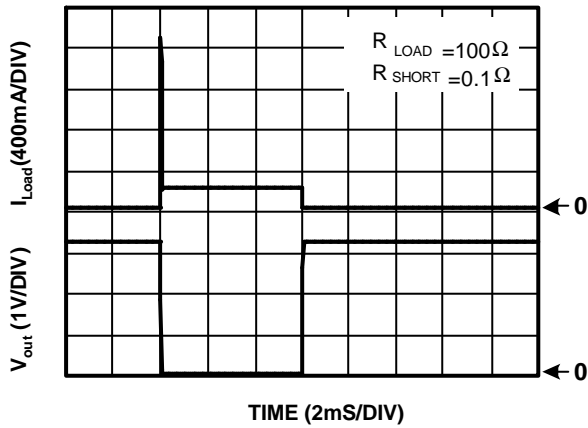
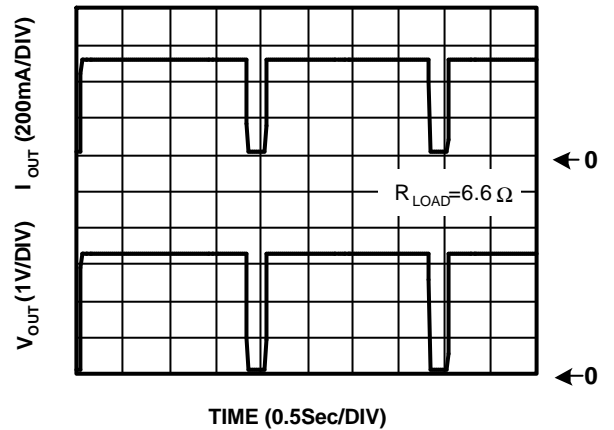
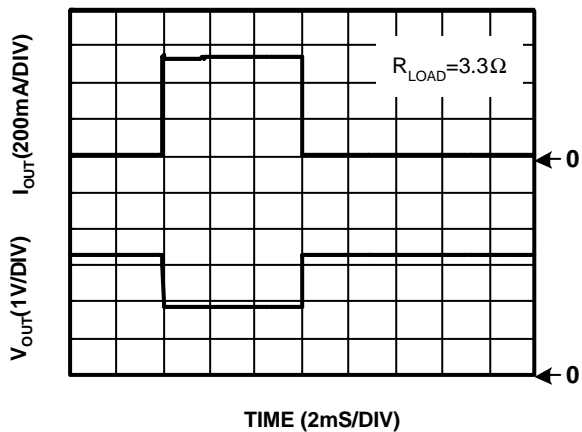
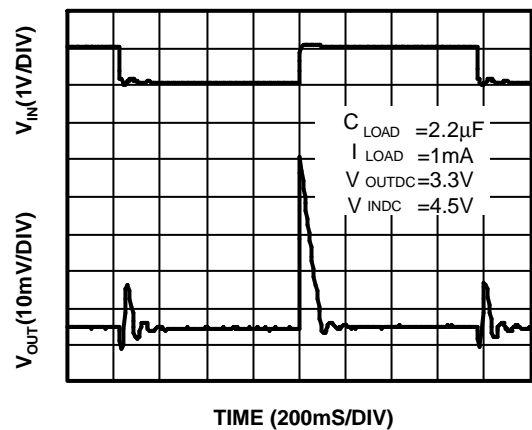
**Power Supply Rejection Ratio**

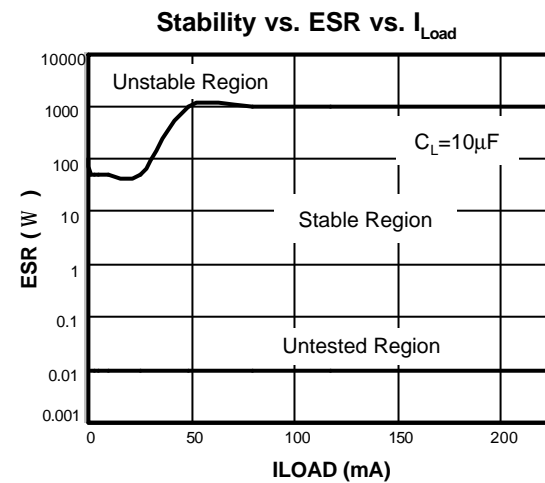
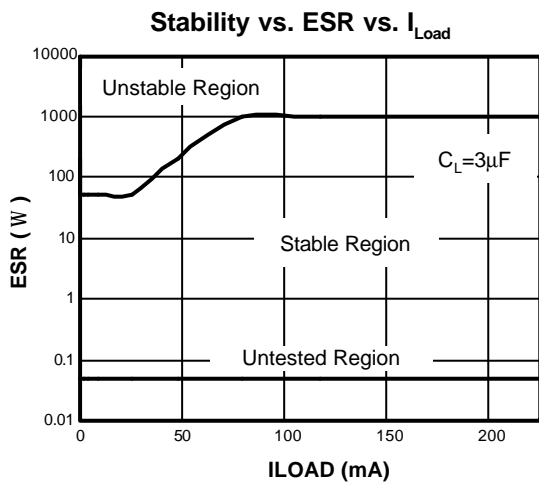
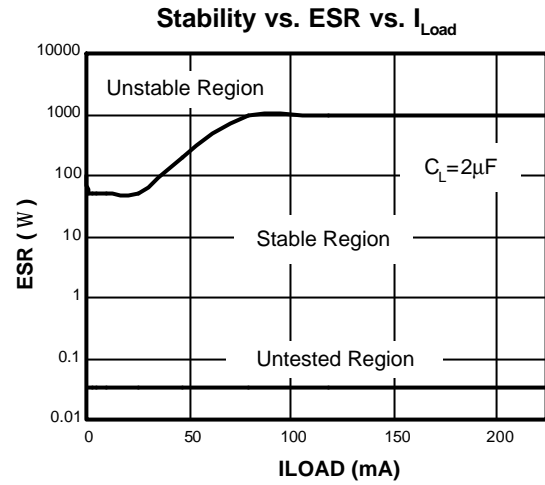
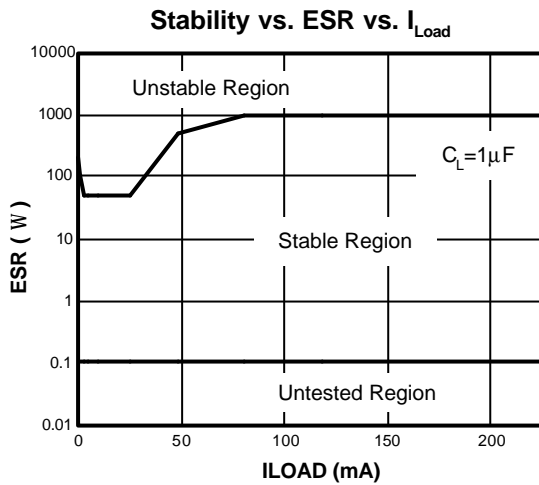
**Chip Enable Transient Response**

**Drop Out Voltage vs. Output Voltage**

**Drop Out Voltage vs. Load Current**



**Noise Measurement**

**Safe Operating Area**

**Short Circuit Response**

**Overtemperature Shutdown**

**Current Limit Response**

**Line Transient Response**



**External Resistor Divider Table**

R1 (K Ohm)	1	2	5	10	20	50	100	200	500	1000
Vout	R2(K Ohm)=(1.215*R1(K Ohm))/(Vout-1.215)									
1.30	14.29	28.59	71.47	142.94	285.88	714.71				
1.35	9.00	18.00	45.00	90.00	180.00	450.00				
1.40	6.57	13.14	32.84	65.68	131.35	328.38				
1.45	5.17	10.34	25.85	51.70	103.40	258.51	517.02			
1.50	4.26	8.53	21.32	42.63	85.26	213.16	426.32	852.63		
1.55	3.63	7.25	18.13	36.27	72.54	181.34	362.69	725.37		
1.60	3.16	6.31	15.78	31.56	63.12	157.79	315.58	631.17		
1.65	2.79	5.59	13.97	27.93	55.86	139.66	279.31	558.62		
1.70	2.51	5.01	12.53	25.05	50.10	125.26	250.52	501.03		
1.75	2.27	4.54	11.36	22.71	45.42	113.55	227.10	454.21		
1.80	2.08	4.15	10.38	20.77	41.54	103.85	207.69	415.38		
1.85	1.91	3.83	9.57	19.13	38.27	95.67	191.34	382.68		
1.90	1.77	3.55	8.87	17.74	35.47	88.69	177.37	354.74		
1.95	1.65	3.31	8.27	16.53	33.06	82.65	165.31	330.61	826.53	
2.00	1.55	3.10	7.74	15.48	30.96	77.39	154.78	309.55	773.89	
2.05	1.46	2.91	7.28	14.55	29.10	72.75	145.51	291.02	727.54	
2.10	1.37	2.75	6.86	13.73	27.46	68.64	137.29	274.58	686.44	
2.15	1.30	2.60	6.50	12.99	25.99	64.97	129.95	259.89	649.73	
2.20	1.23	2.47	6.17	12.34	24.67	61.68	123.35	246.70	616.75	
2.25	1.17	2.35	5.87	11.74	23.48	58.70	117.39	234.78	586.96	
2.30	1.12	2.24	5.60	11.20	22.40	55.99	111.98	223.96	559.91	
2.35	1.07	2.14	5.35	10.70	21.41	53.52	107.05	214.10	535.24	
2.40	1.03	2.05	5.13	10.25	20.51	51.27	102.53	205.06	512.66	
2.45	0.98	1.97	4.92	9.84	19.68	49.19	98.38	196.76	491.90	
2.50	0.95	1.89	4.73	9.46	18.91	47.28	94.55	189.11	472.76	
2.55	0.91	1.82	4.55	9.10	18.20	45.51	91.01	182.02	455.06	
2.60	0.88	1.75	4.39	8.77	17.55	43.86	87.73	175.45	438.63	877.26
2.65	0.85	1.69	4.23	8.47	16.93	42.33	84.67	169.34	423.34	846.69
2.70	0.82	1.64	4.09	8.18	16.36	40.91	81.82	163.64	409.09	818.18
2.75	0.79	1.58	3.96	7.92	15.83	39.58	79.15	158.31	395.77	791.53
2.80	0.77	1.53	3.83	7.67	15.33	38.33	76.66	153.31	383.28	766.56
2.85	0.74	1.49	3.72	7.43	14.86	37.16	74.31	148.62	371.56	743.12
2.90	0.72	1.44	3.61	7.21	14.42	36.05	72.11	144.21	360.53	721.07
2.95	0.70	1.40	3.50	7.00	14.01	35.01	70.03	140.06	350.14	700.29
3.00	0.68	1.36	3.40	6.81	13.61	34.03	68.07	136.13	340.34	680.67
3.05	0.66	1.32	3.31	6.62	13.24	33.11	66.21	132.43	331.06	662.13
3.10	0.64	1.29	3.22	6.45	12.89	32.23	64.46	128.91	322.28	644.56

**External Resistor Divider Table (contd.)**

R1 (K Ohm)	1	2	5	10	20	50	100	200	500	1000
Vout	$R2(K\text{ Ohm})=(1.215 \cdot R1(K\text{ Ohm})) / (Vout-1.215)$									
3.15	0.63	1.26	3.14	6.28	12.56	31.40	62.79	125.58	313.95	627.91
3.20	0.61	1.22	3.06	6.12	12.24	30.60	61.21	122.42	306.05	612.09
3.25	0.60	1.19	2.99	5.97	11.94	29.85	59.71	119.41	298.53	597.05
3.30	0.58	1.17	2.91	5.83	11.65	29.14	58.27	116.55	291.37	582.73
3.35	0.57	1.14	2.85	5.69	11.38	28.45	56.91	113.82	284.54	569.09
3.40	0.56	1.11	2.78	5.56	11.12	27.80	55.61	111.21	278.03	556.06
3.45	0.54	1.09	2.72	5.44	10.87	27.18	54.36	108.72	271.81	543.62
3.50	0.53	1.06	2.66	5.32	10.63	26.59	53.17	106.35	265.86	531.73
3.55	0.52	1.04	2.60	5.20	10.41	26.02	52.03	104.07	260.17	520.34
3.60	0.51	1.02	2.55	5.09	10.19	25.47	50.94	101.89	254.72	509.43
3.65	0.50	1.00	2.49	4.99	9.98	24.95	49.90	99.79	249.49	498.97
3.70	0.49	0.98	2.44	4.89	9.78	24.45	48.89	97.79	244.47	488.93
3.75	0.48	0.96	2.40	4.79	9.59	23.96	47.93	95.86	239.64	479.29
3.80	0.47	0.94	2.35	4.70	9.40	23.50	47.00	94.00	235.01	470.02
3.85	0.46	0.92	2.31	4.61	9.22	23.06	46.11	92.22	230.55	461.10
3.90	0.45	0.91	2.26	4.53	9.05	22.63	45.25	90.50	226.26	452.51
3.95	0.44	0.89	2.22	4.44	8.88	22.21	44.42	88.85	222.12	444.24
4.00	0.44	0.87	2.18	4.36	8.73	21.81	43.63	87.25	218.13	436.27
4.05	0.43	0.86	2.14	4.29	8.57	21.43	42.86	85.71	214.29	428.57
4.10	0.42	0.84	2.11	4.21	8.42	21.06	42.11	84.23	210.57	421.14
4.15	0.41	0.83	2.07	4.14	8.28	20.70	41.40	82.79	206.98	413.97
4.20	0.41	0.81	2.04	4.07	8.14	20.35	40.70	81.41	203.52	407.04
4.25	0.40	0.80	2.00	4.00	8.01	20.02	40.03	80.07	200.16	400.33
4.30	0.39	0.79	1.97	3.94	7.88	19.69	39.38	78.77	196.92	393.84
4.35	0.39	0.78	1.94	3.88	7.75	19.38	38.76	77.51	193.78	387.56
4.40	0.38	0.76	1.91	3.81	7.63	19.07	38.15	76.30	190.74	381.48
4.45	0.38	0.75	1.88	3.76	7.51	18.78	37.56	75.12	187.79	375.58
4.50	0.37	0.74	1.85	3.70	7.40	18.49	36.99	73.97	184.93	369.86
4.55	0.36	0.73	1.82	3.64	7.29	18.22	36.43	72.86	182.16	364.32
4.60	0.36	0.72	1.79	3.59	7.18	17.95	35.89	71.79	179.47	358.94
4.65	0.35	0.71	1.77	3.54	7.07	17.69	35.37	70.74	176.86	353.71
4.70	0.35	0.70	1.74	3.49	6.97	17.43	34.86	69.73	174.32	348.64
4.75	0.34	0.69	1.72	3.44	6.87	17.19	34.37	68.74	171.85	343.71
4.80	0.34	0.68	1.69	3.39	6.78	16.95	33.89	67.78	169.46	338.91
4.85	0.33	0.67	1.67	3.34	6.69	16.71	33.43	66.85	167.13	334.25
4.90	0.33	0.66	1.65	3.30	6.59	16.49	32.97	65.94	164.86	329.72
4.95	0.33	0.65	1.63	3.25	6.51	16.27	32.53	65.06	162.65	325.30
5.00	0.32	0.64	1.61	3.21	6.42	16.05	32.10	64.20	160.50	321.00

Note: Small load (greater than 2 mA) is necessary as R1 or R2 is larger than 50 Kohm. Otherwise, output voltage probably cannot be pulled down to 0 V on disable mode.

**■ Date Code Rule**

Marking			Date Code		Year
A	A	A	W	W	xxx0
A	A	A	W	<u>W</u>	xxx1
A	A	A	<u>W</u>	W	xxx2
A	A	A	<u>W</u>	<u>W</u>	xxx3
A	A	<u>A</u>	W	W	xxx4
A	A	<u>A</u>	W	<u>W</u>	xxx5
A	A	<u>A</u>	<u>W</u>	W	xxx6
A	A	<u>A</u>	<u>W</u>	<u>W</u>	xxx7
A	<u>A</u>	A	W	W	xxx8
A	<u>A</u>	A	W	<u>W</u>	xxx9

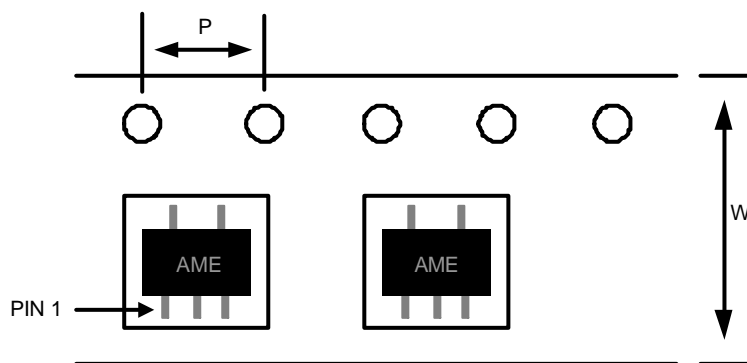
**■ Tape and Reel Dimension**
**SOT-25**

**Carrier Tape, Number of Components Per Reel and Reel Size**

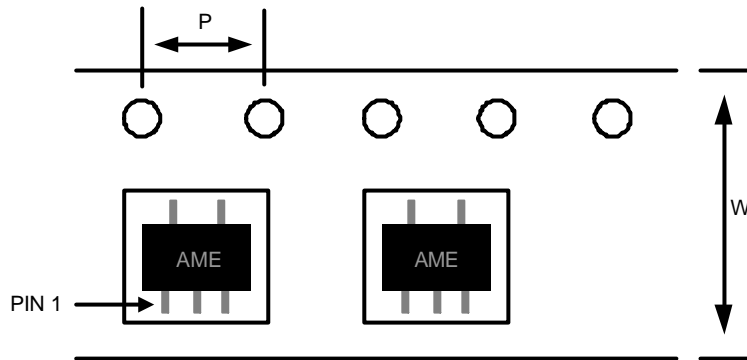
Package	Carrier Width (W)	Pitch (P)	Part Per Full Reel	Reel Size
SOT-25	8.0±0.1 mm	4.0±0.1 mm	3000pcs	180±1 mm

**■ Tape and Reel Dimension**
**TSOT-25**

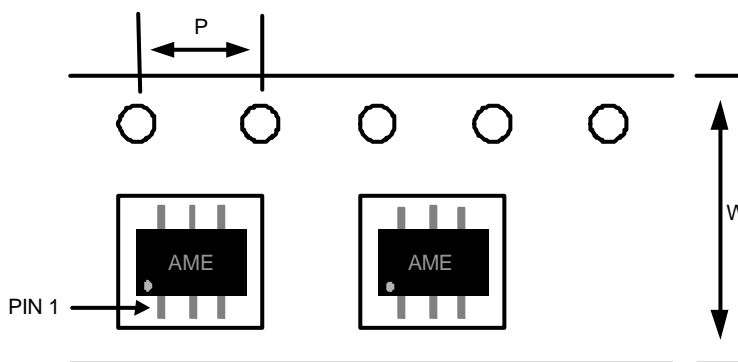
**Carrier Tape, Number of Components Per Reel and Reel Size**

Package	Carrier Width (W)	Pitch (P)	Part Per Full Reel	Reel Size
TSOT-25	8.0±0.1 mm	4.0±0.1 mm	3000pcs	180±1 mm

**SOT-26**

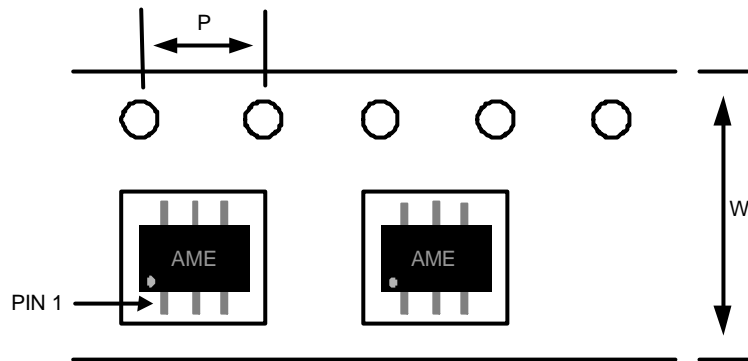
**Carrier Tape, Number of Components Per Reel and Reel Size**

Package	Carrier Width (W)	Pitch (P)	Part Per Full Reel	Reel Size
SOT-26	8.0±0.1 mm	4.0±0.1 mm	3000pcs	180±1 mm

**■ Tape and Reel Dimension**
**TSOT-26**

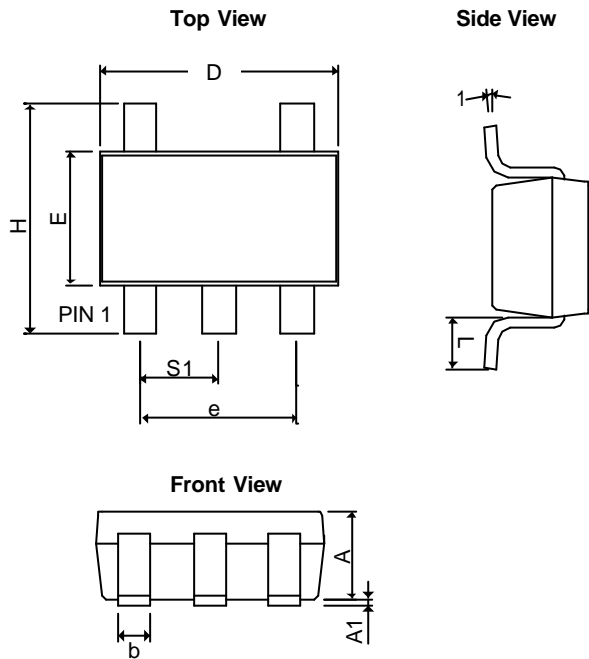
**Carrier Tape, Number of Components Per Reel and Reel Size**

Package	Carrier Width (W)	Pitch (P)	Part Per Full Reel	Reel Size
TSOT-26	8.0±0.1 mm	4.0±0.1 mm	3000pcs	180±1 mm

**■ Package Dimension**
**SOT-25**

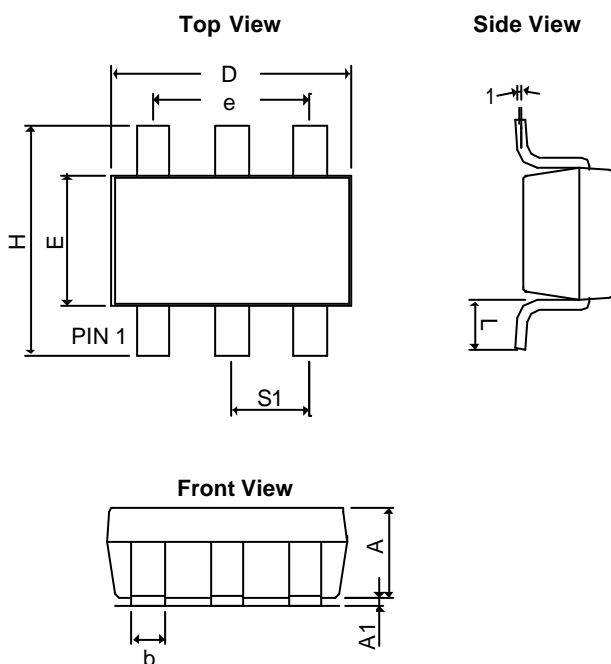
SYMBOLS	MILLIMETERS		INCHES	
	MIN	MAX	MIN	MAX
A	1.20REF		0.0472REF	
A <sub>1</sub>	0.00	0.15	0.0000	0.0059
b	0.30	0.55	0.0118	0.0217
D	2.70	3.10	0.1063	0.1220
E	1.40	1.80	0.0551	0.0709
e	1.90 BSC		0.07480 BSC	
H	2.60	3.00	0.10236	0.11811
L	0.37BSC		0.0146BSC	
q1	0°	10°	0°	10°
S <sub>1</sub>	0.95BSC		0.0374BSC	

**SOT-26**

SYMBOLS	MILLIMETERS		INCHES	
	MIN	MAX	MIN	MAX
A	1.20REF		0.0472REF	
A <sub>1</sub>	0.00	0.15	0.0000	0.0059
b	0.30	0.55	0.0118	0.0217
D	2.70	3.10	0.1063	0.1220
E	1.40	1.80	0.0551	0.0709
e	1.90 BSC		0.0748 BSC	
H	2.60	3.00	0.10236	0.11811
L	0.37REF		0.0146REF	
q1	0°	10°	0°	10°
S <sub>1</sub>	0.95REF		0.0374REF	

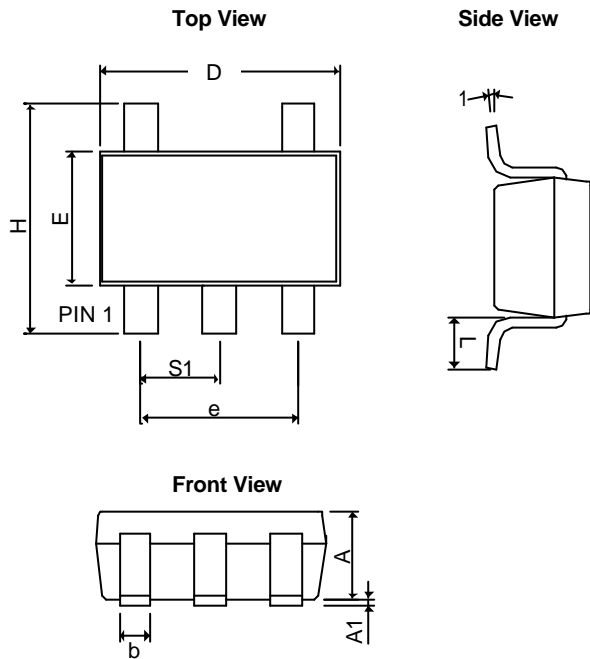

**■ Package Dimension**
**TSOT-25**

SYMBOLS	MILLIMETERS		INCHES	
	MIN	MAX	MIN	MAX
$A+A_1$	0.90	1.25	0.0354	0.0492
$b$	0.30	0.50	0.0118	0.0197
$D$	2.70	3.10	0.1063	0.1220
$E$	1.40	1.80	0.0551	0.0709
$e$	1.90 BSC		0.07480 BSC	
$H$	2.40	3.00	0.09449	0.11811
$L$	0.35BSC		0.0138BSC	
$\delta 1$	0°	10°	0°	10°
$S_1$	0.95BSC		0.0374BSC	

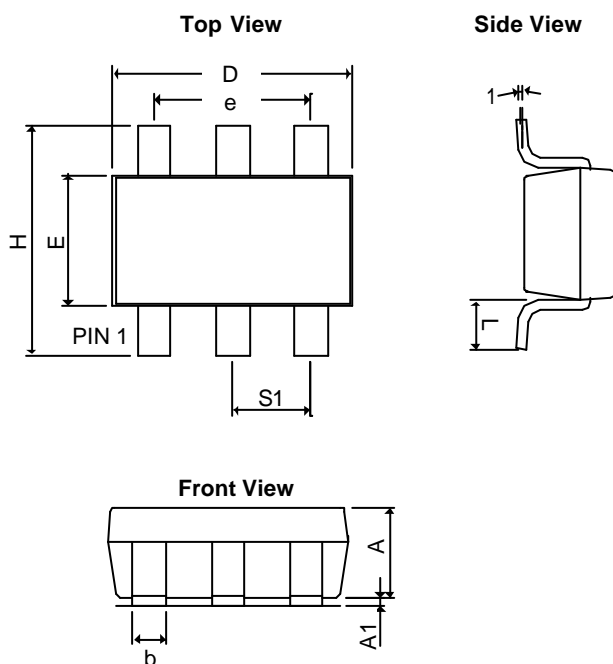
**TSOT-26**

SYMBOLS	MILLIMETERS		INCHES	
	MIN	MAX	MIN	MAX
$A+A_1$	0.90	1.25	0.0354	0.0492
$b$	0.30	0.50	0.0118	0.0197
$D$	2.70	3.10	0.1063	0.1220
$E$	1.40	1.80	0.0551	0.0709
$e$	1.90 BSC		0.07480 BSC	
$H$	2.40	3.00	0.09449	0.11811
$L$	0.35BSC		0.0138BSC	
$\delta 1$	0°	10°	0°	10°
$S_1$	0.95BSC		0.0374BSC	



**www.ame.com.tw**  
**E-Mail: sales@ame.com.tw**

Life Support Policy:

These products of AME, Inc. are not authorized for use as critical components in life-support devices or systems, without the express written approval of the president of AME, Inc.

AME, Inc. reserves the right to make changes in the circuitry and specifications of its devices and advises its customers to obtain the latest version of relevant information.

© AME, Inc. , January 2012  
Document: 2006/2095-DS8804-K.04

**Corporate Headquarter**  
**AME, Inc.**

8F, 12, WenHu St., Nei Hu  
Taipei, Taiwan. 114  
Tel: 886 2 2627-8687  
Fax: 886 2 2659-2989