

■ General Description

The AME8847 of positive, linear regulators feature low quiescent current (30 μ A typ.) with low dropout voltage, making them ideal for battery applications. The space-saving SOT-223 & SOT-89 packages are attractive for "Pocket" and "Hand Held" applications.

These rugged devices have both thermal shutdown, and current fold-back to prevent device failure under the "Worst" operating conditions.

The AME8847 is stable with an output capacitance of 2.2 μ F or greater.

■ Features

- Very Low Dropout Voltage
- Guaranteed 800mA Output
- Accurate to within $\pm 1.5\%$
- 30 μ A Quiescent Current
- Over-Temperature Shutdown
- Current Limiting
- Short Circuit Current Fold-back
- Space-Saving SOT-223 & SOT-89 Packages
- Factory Pre-set Output Voltages
- Low Temperature Coefficient
- All AME's Lead Free Products Meet RoHS Standards

■ Applications

- Instrumentation
- Portable Electronics
- Wireless Devices
- Cordless Phones
- PC Peripherals
- Battery Powered Widgets

■ Functional Block Diagram

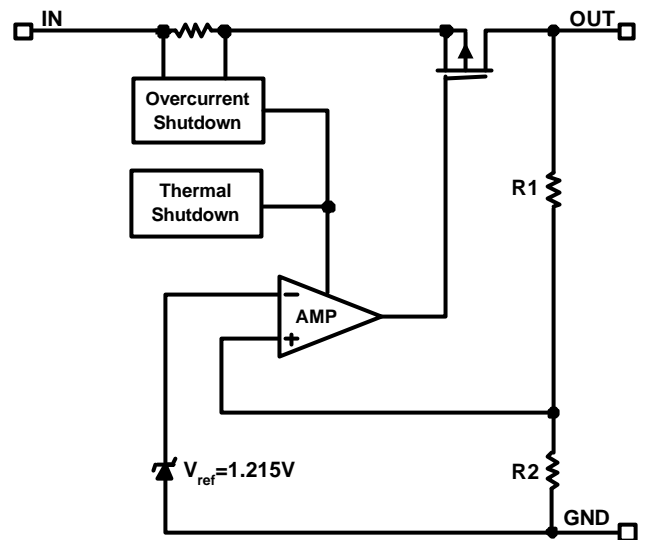

■ Typical Application

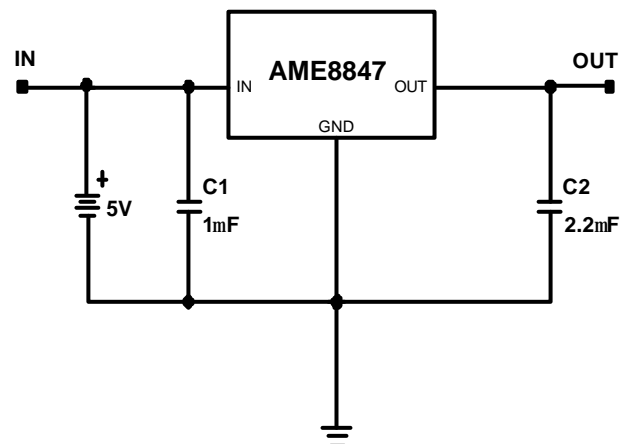

■ Pin Configuration

AME8847AEGT

1. GND
2. OUT(TAB)
3. IN

* Die Attach:
Non-Conductive Epoxy

AME8847AEFT

1. GND
2. IN(TAB)
3. OUT

* Die Attach:
Non-Conductive Epoxy

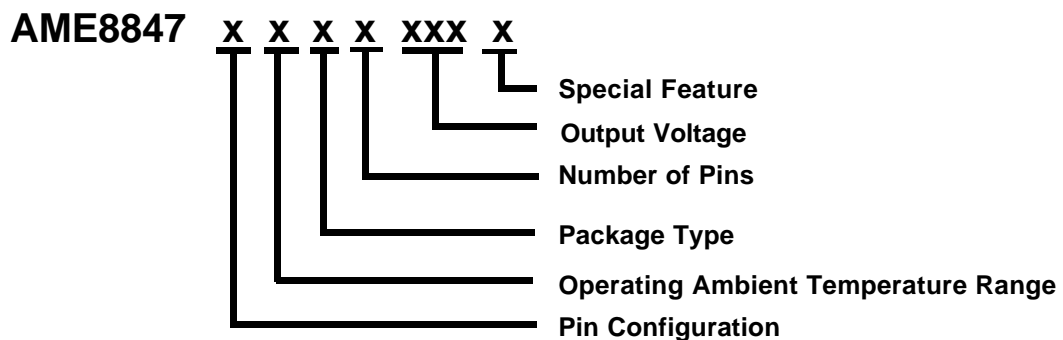
■ Ordering Information

Pin Configuration	Operating Ambient Temperature Range	Package Type	Number of Pins	Output Voltage	Special Feature
A: 1. GND (SOT-89) 2. IN 3. OUT A: 1. GND (SOT-223) 2. OUT 3. IN	E: -40°C to +85°C	F: SOT-89 G: SOT-223	T: 3	180: V=1.8V 250: V=2.5V 330: V=3.3V	Z: Lead Free



AME8847

800mA CMOS LDO

■ Ordering Information

Part Number	Marking*	Output Voltage	Package	Operating Ambient Temperature Range
AME8847AEFT180Z	A8847 A18ww	1.8V	SOT-89	- 40°C to +85°C
AME8847AEGT180Z	BHlyww	1.8V	SOT-223	- 40°C to +85°C
AME8847AEFT250Z	A8847 A25ww	2.5V	SOT-89	- 40°C to +85°C
AME8847AEGT250Z	BHJyww	2.5V	SOT-223	- 40°C to +85°C
AME8847AEFT330Z	A8847 A33ww	3.3V	SOT-89	- 40°C to +85°C
AME8847AEGT330Z	BFWyww	3.3V	SOT-223	- 40°C to +85°C

Note: ww & yww represents the date code pls refer to Date Code Rule on Package Dimension.

* A line on top of the first letter represents lead free plating such as A8847

Please consult AME sales office or authorized Rep./Distributor for output voltage and package type availability.

■ Absolute Maximum Ratings

Parameter	Maximum	Unit
Input Voltage	8	V
Output Current	1	A
Input, Output Voltage	GND - 0.3 to $V_{IN} + 0.3$	V
ESD Classification	B*	

Caution: Stress above the listed absolute maximum rating may cause permanent damage to the device.

*HBM B:2000V~3999V

■ Recommended Operating Conditions

Parameter	Symbol	Rating	Unit
Ambient Temperature Range	T_A	- 40 to +85	°C
Junction Temperature Range	T_J	- 40 to +125	°C
Storage Temperature Range	T_{STG}	- 65 to +150	°C

■ Thermal Information

Parameter	Package	Die Attach	Symbol	Maximum	Unit
Thermal Resistance* (Junction to Case)	SOT-89	Non-Conductive Epoxy	θ_{JC}	46	°C / W
	SOT-223			31	
Thermal Resistance (Junction to Ambient)	SOT-89		θ_{JA}	180	°C / W
	SOT-223			135	
Internal Power Dissipation	SOT-89		P_D	550	mW
	SOT-223			800	
Solder Iron(10 Sec)**				350	°C

* Measure θ_{JC} on backside center of tab.

** MIL-STD-202G 210F

■ Electrical Specifications
 $T_A = 25^\circ\text{C}$ unless otherwise noted

Parameter	Symbol	Test Condition	Min	Typ	Max	Units	
Input Voltage	V_{IN}		Note 1		7	V	
Output Voltage Accuracy	V_{OUT}	$I_{OUT} = 1\text{mA}$	-1.5		1.5	%	
Dropout Voltage	V_{DROP}	$I_{OUT} = 800\text{mA}$ $V_{OUT} = V_{OUT(NOM)} - 2.0\%$	$1.8\text{V} \leq V_{OUT(NOM)} \leq 2.0\text{V}$	See chart	1400	mV	
			$2.0\text{V} < V_{OUT(NOM)} \leq 2.8\text{V}$		1000		
			$2.8\text{V} < V_{OUT(NOM)}$		800		
Output Current	I_{OUT}	$V_{OUT} \geq 1.8\text{V}$	800			mA	
Output Current Limit	I_{LIM}	$V_{OUT} \geq 1.8\text{V}$	900			mA	
Output Short Circuit Current	I_{SC}	$V_{OUT} < 0.8\text{V}$		400	800	mA	
Quiescent Current	I_Q	$I_{OUT} = 0\text{mA}$		30	50	μA	
Ground Pin Current	I_{GND}	$I_{OUT} = 1\text{mA}$ to 800mA		35		μA	
Output Voltage Line Regulation	REG_{LINE}	$I_{OUT} = 1\text{mA}$ $V_{IN} = V_{OUT} + 1$ to $V_{OUT} + 2$	$1.8\text{V} \leq V_{OUT} \leq 2.0\text{V}$	-0.15		0.15	%
			$2.0\text{V} < V_{OUT} < 4.0\text{V}$	-0.1	0.02	0.1	
			$V_{OUT} \geq 4.0\text{V}$	-0.4	0.2	0.4	
Output Voltage Load Regulation	REG_{LOAD}	$I_{OUT} = 1\text{mA}$ to 800mA		0.2	1	%	
Thermal Shutdown Temperature	T_{SHDN}			150		$^\circ\text{C}$	
Temperature Hysteresis	T_{HYS}			30		$^\circ\text{C}$	
Output Voltage Temperature Coefficient	T_C			30		ppm/ $^\circ\text{C}$	
Power Supply Ripple Rejection	PSRR	$I_{OUT} = 100\text{mA}$ $C_{OUT} = 2.2\mu\text{F}$	$f = 100\text{Hz}$		60	dB	
			$f = 1\text{KHz}$		50		
			$f = 10\text{KHz}$		20		
Output Voltage Noise	e_N	$f = 10\text{Hz}$ to 100KHz $I_{OUT} = 10\text{mA}$			30	μVrms	

 Note1: $V_{IN(MIN)} = V_{OUT} + V_{DROP}$

Note2: To prevent the Short Circuit Current protection feature from being prematurely activated, the input voltage must be applied before a current source load is applied.

■ Detailed Description

The AME8847 of CMOS regulators contains a PMOS pass transistor, voltage reference, error amplifier, over-current protection, and thermal shutdown.

The P-channel pass transistor receives data from the error amplifier, over-current shutdown, and thermal protection circuits. During normal operation, the error amplifier compares the output voltage to a precision reference. Over-current and Thermal shutdown circuits become active when the junction temperature exceeds 150°C, or the current exceeds 900mA. During thermal shutdown, the output voltage remains low. Normal operation is restored when the junction temperature drops below 120°C.

The AME8847 switches from voltage mode to current mode when the load exceeds the rated output current. This prevents over-stress. The AME8847 also incorporates current foldback to reduce power dissipation when the output is short circuited. This feature becomes active when the output drops below 0.8 volts, and reduces the current flow by 65%. Full current is restored when the voltage exceeds 0.8 volts.

■ External Capacitors

The AME8847 is stable with an output capacitor to ground of 2.2 μ F or greater. Ceramic capacitors have the lowest ESR, and will offer the best AC performance. Conversely, Aluminum Electrolytic capacitors exhibit the highest ESR, resulting in the poorest AC response. Unfortunately, large value ceramic capacitors are comparatively expensive. One option is to parallel a 0.1 μ F ceramic capacitor with a 10 μ F Aluminum Electrolytic. The benefit is low ESR, high capacitance, and low overall cost.

A second capacitor is recommended between the input and ground to stabilize V_{in} . The input capacitor should be at least 0.1 μ F to have a beneficial effect.

All capacitors should be placed in close proximity to the pins. A "Quiet" ground termination is desirable. This can be achieved with a "Star" connection.

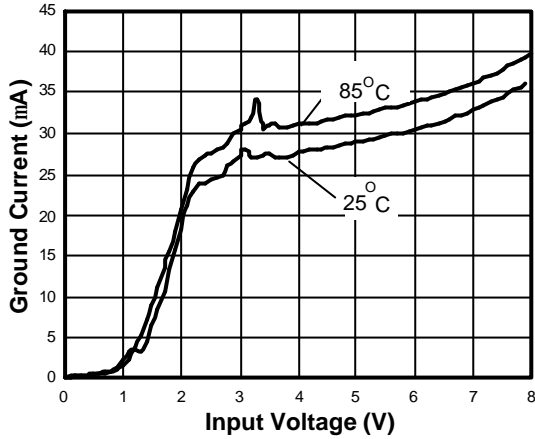
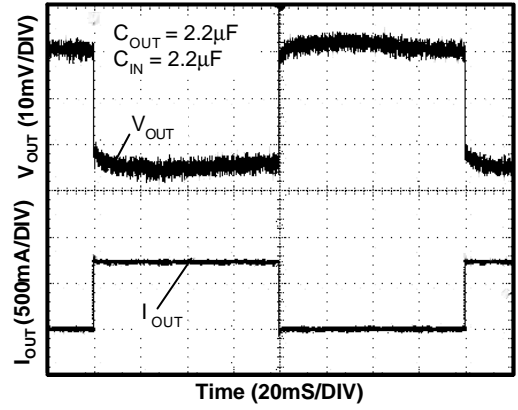
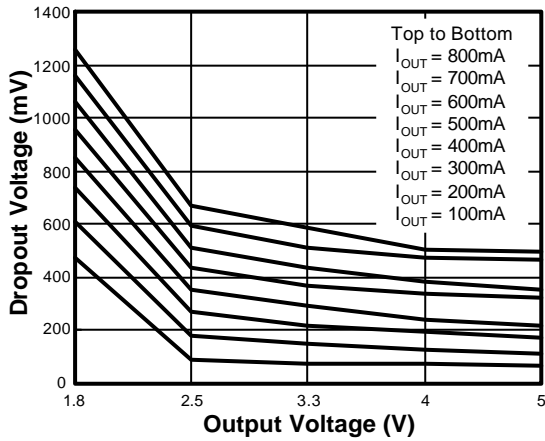
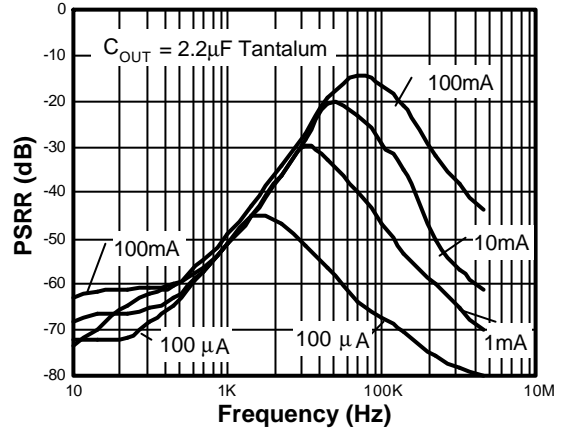
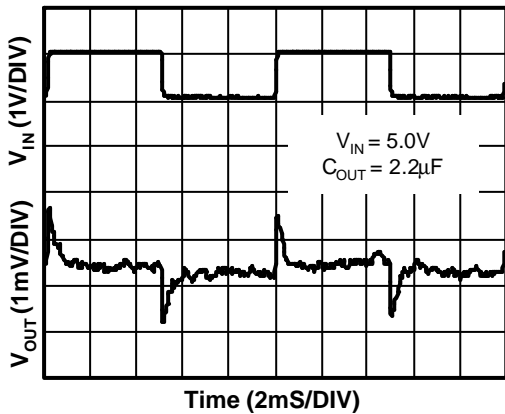
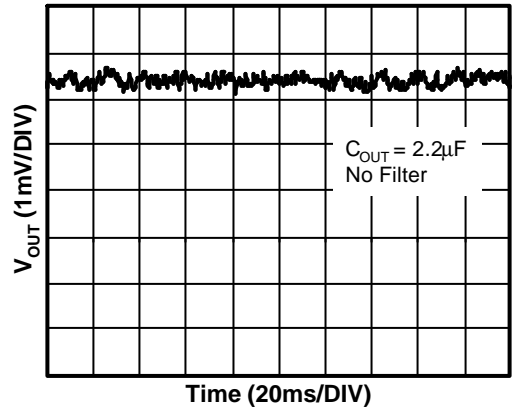
Ground Current vs. Input Voltage

Load Step (1mA-800mA)

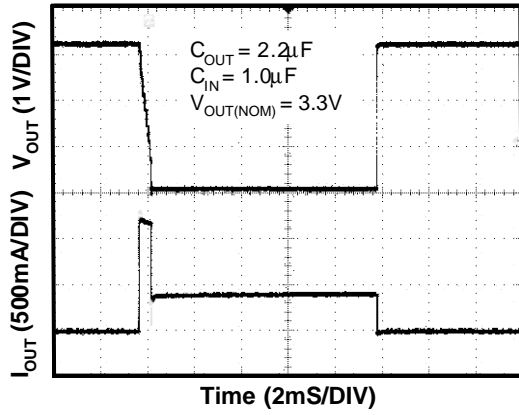
Dropout Voltage vs. Output Voltage

Power Supply Ripple Rejection Ratio

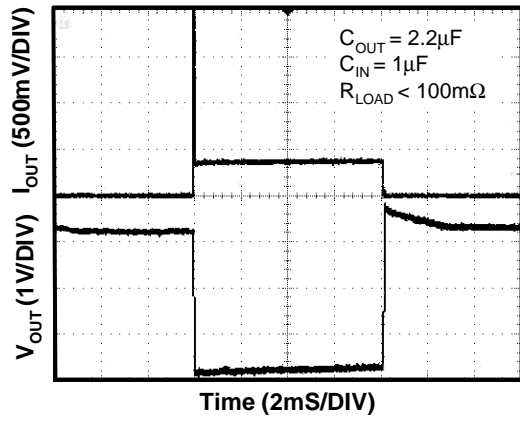
Line Transient Response

Noise Measurement

Current Limit Response



Short Circuit Response



■ Date Code Rule

Marking			Date Code		Year
A	A	A	W	W	xxx0
A	A	A	W	<u>W</u>	xxx1
A	A	A	<u>W</u>	W	xxx2
A	A	A	<u>W</u>	<u>W</u>	xxx3
A	A	<u>A</u>	W	W	xxx4
A	A	<u>A</u>	W	<u>W</u>	xxx5
A	A	<u>A</u>	<u>W</u>	W	xxx6
A	A	<u>A</u>	<u>W</u>	<u>W</u>	xxx7
A	<u>A</u>	A	W	W	xxx8
A	<u>A</u>	A	W	<u>W</u>	xxx9

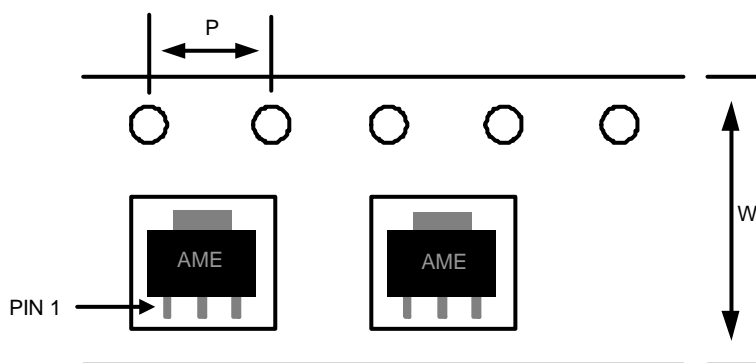
■ Tape and Reel Dimension
SOT-89

Carrier Tape, Number of Components Per Reel and Reel Size

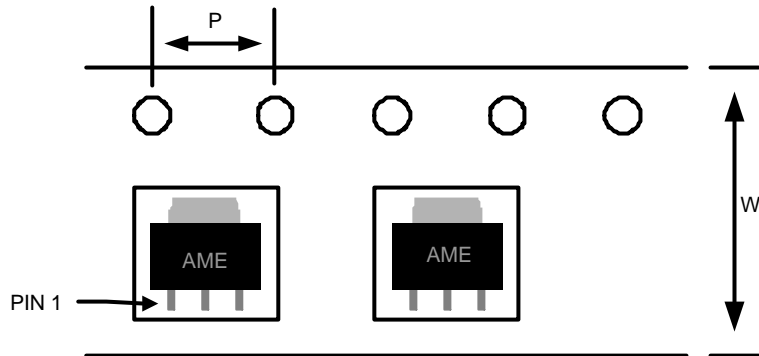
Package	Carrier Width (W)	Pitch (P)	Part Per Full Reel	Reel Size
SOT-89	12.0±0.1 mm	4.0±0.1 mm	1000pcs	180±1 mm

■ Tape and Reel Dimension
SOT-223

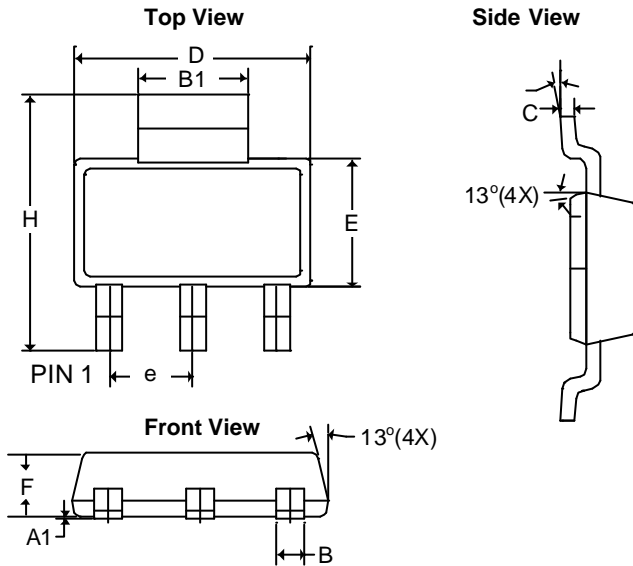
Carrier Tape, Number of Components Per Reel and Reel Size

Package	Carrier Width (W)	Pitch (P)	Part Per Full Reel	Reel Size
SOT-223	12.0±0.1 mm	4.0±0.1 mm	2500pcs	330±1 mm

■ Package Dimension
SOT-223

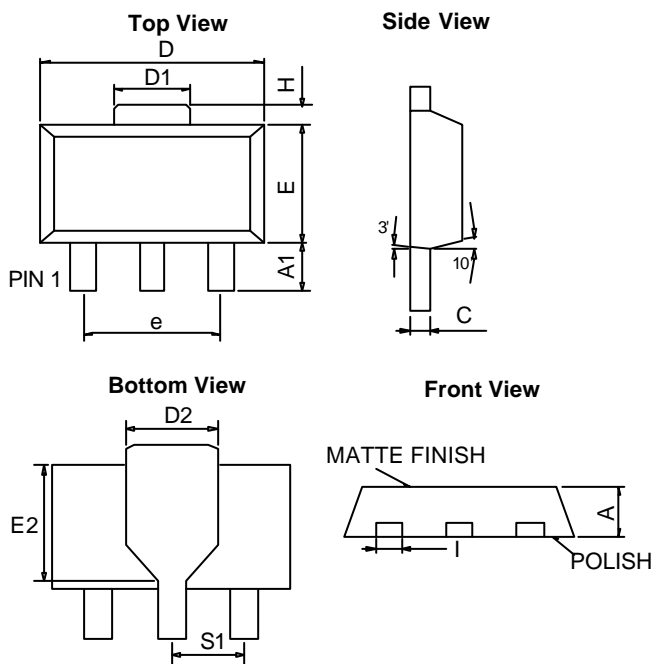
SYMBOLS	MILLIMETERS		INCHES	
	MIN	MAX	MIN	MAX
A ₁	0.01	0.10	0.0004	0.0039
B	0.60	0.84	0.0236	0.0330
B ₁	2.90	3.15	0.1140	0.1240
C	0.24	0.38	0.0094	0.0150
D	6.30	6.71	0.2480	0.2640
E	3.30	3.71	0.1299	0.1460
e	2.30 BSC		0.0906 BSC	
F	1.40	1.80	0.0551	0.0709
H	6.70	7.30	0.2638	0.2874
q	0°	10°	0°	10°

SOT-89

SYMBOLS	MILLIMETERS		INCHES	
	MIN	MAX	MIN	MAX
A	1.39	1.60	0.05472	0.06299
A ₁	0.8 REF		0.03150 REF	
C	0.35	0.44	0.01378	0.01732
D	4.39	4.60	0.17283	0.18110
D ₁	1.35	1.83	0.05315	0.07205
E	2.28	2.60	0.08976	0.10236
I	0.36	0.56	0.01417	0.02204
e	3.00 REF		0.11811 REF	
H	0.70 REF		0.02756 REF	
S1	1.50 REF		0.05906 REF	
E2	2.05	2.60	0.08071	0.10236
D2	1.50	1.85	0.05905	0.07283



www.ame.com.tw
E-Mail: sales@ame.com.tw

Life Support Policy:

These products of AME, Inc. are not authorized for use as critical components in life-support devices or systems, without the express written approval of the president of AME, Inc.

AME, Inc. reserves the right to make changes in the circuitry and specifications of its devices and advises its customers to obtain the latest version of relevant information.

© AME, Inc. , November 2008
Document: 2095-DS8847-A.03

Corporate Headquarter
AME, Inc.

2F, 302 Rui-Guang Road, Nei-Hu District
Taipei 114, Taiwan.
Tel : 886 2 2627-8687
Fax: 886 2 2659-2989